

InstructionManual

ENGLISH

**XL1003 - XL1005
XEBPC-16EU-D
XEBPC-16EU-M
XEBPL-16EU-D
XEBPL-16EU-M**

ATTENTION: Read the instruction before use



| | |
|----------------------------------|----------|
| INTRODUCTION | 3 |
| EXPLANATION OF PICTOGRAMS | 3 |
| FORWARD | 4 |
| SAFETY REGULATIONS | 4 |



| | |
|---------------------------------------|----------|
| INSTRUCTIONS FOR THE INSTALLER | 6 |
|---------------------------------------|----------|



| | |
|----------------------------------|-----------|
| INSTRUCTIONS FOR THE USER | 21 |
|----------------------------------|-----------|

INTRODUCTION

Dear Customer,

We would like to congratulate and thank you for choosing to purchase an oven in the **BakerTop™ / BakerLux™** range; we hope this is just the beginning of a fruitful and long-lasting partnership.

Your prover allows accurate and precise control over leavening temperature and humidity, drastically reducing times when employing traditional methods. Excellent results that are true to tradition are guaranteed.

The prover can be integrated with **BakerTop™** or **BakerLux™** ovens to achieve a complete baking station that handles any need.

UNOX S.p.A.

Dealer:

Installer:

Installation date:

Explanation of pictograms



Danger! Situation presenting immediate danger, or a hazardous situation which could cause injury or death.



Danger: fire hazard!



Danger: electric shock!



Read operator's manual



Danger: risk of burns



Tips and useful information



Protective earth symbol



Equipotentially symbol



Consult other chapter



Forward

This booklet shows the installation and use of provers mod. **XL1003 - XEBPC-16EU-M - XEBPL-16EU-M *Manual*** and **XL1005 - XEBPC-16EU-D - XEBPL-16EU-D *Dynamic***.

The **XL1003 - XEBPC-16EU-M - XEBPL-16EU-M *Manual*** models have manual controls.

The **XL1005 - XEBPC-16EU-D - XEBPL-16EU-D *Dynamic*** models have digital controls.

The installation and user instructions are valid for all models unless otherwise specified.

Safety regulations



Safety regulations for installation and maintenance

- **Read this guide carefully before installing or maintaining the appliance, and conserve this guide with care for any future consultation of users.**
- **All installation, assembly and non-routine maintenance operation must be performed exclusively by qualified technicians that are authorised by UNOX, in compliance with the regulations in force in the user country, and with respect to the regulations on systems and work safety.**
- Before starting installation or maintenance disconnect the appliance from any electrical or plumbing connections.
- Check that systems are compliant to the installation country standards and to the specifications indicated on the appliance rating plate before installing the appliance.
- Interventions, alterations or modifications not expressly authorized that do not comply with the indications in this manual shall invalidate the guarantee.
- Installation or maintenance that fails to respect the indications in this manual may cause damage, injury or fatal accidents.
- Persons not involved with appliance installation may not pass through or occupy the work area during appliance assembly.
- Given its potential danger, the package material must be kept out of reach of children or animals, and properly disposed of as called for by local regulation.
- The ratings plate provides essential technical information that is of utmost importance for any appliance maintenance or repairs. Do not remove, damage or modify the plate.
- Failure to follow these regulations may cause damage or (fatal) injury, subsequently invalidating the guarantee and relieving UNOX of all liability.



Safety regulations for use

- **Read this guide carefully before using the appliance and performing routine maintenance, and conserve this guide with care for any future consultation of users.**
- **Following procedures other than those indicated in this guide to use and clean the appliances is considered inappropriate and may cause damage, injury or fatal accidents; in addition to invalidating the guarantee and relieving UNOX of all liability.**
- This appliance can be used by children aged from 8 years and above and persons with reduced physical, sensory or mental capabilities or lack of experience and knowledge if they have been given supervision or instruction concerning use of the appliance in a safe way and understand the hazard involved. Children shall not play with the appliance. Cleaning and user maintenance shall not be made by children without supervision.
- Children must be supervised to ensure they do not play with the appliance.

- This appliance can be used exclusively
 - by qualified personnel that attend scheduled training courses;
 - for leavening baked goods.
- Monitor the appliance during its entire operation cycle.
- If the appliance does not function or if there are any functional or structural alterations, disconnect the electricity and water supplies and contact an UNOX authorised customer service assistant. Do not attempt to independently repair the appliance. Request UNOX original spare parts for any repairs necessary.
- To ensure that the appliance is in perfect use and in a safe condition, maintenance and inspections should be performed yearly by an authorised customer agent service.
- Maximum tray weight allowed is 5 Kg: heavier loads damage the lateral metal guides and trays.
- Always lock the front wheel brakes of the trolleys after inserting them into the prover chamber and whenever they do not need to be moved.
- Always lock the trays into their guides;



RISK OF BURNS and INJURY!

- While leavening and during cooling of all appliance parts, be careful to:
 - Touch only the appliance handle because all external parts are hot.
 - If it is necessary to open the door, perform this operation slowly and with utmost caution while careful of extremely hot exhaust steam released from the prover cavity.
 - Wear heat resistant clothing appropriate to the use at hand to move containers, accessories and other objects inside the prover cavity.
 - Be careful when removing the trays from the prover cavity; be particularly careful for any spills if the trays contain liquids.
- When the trays contain fluids or are filled when leavening, do not use racks that do not allow you to see inside the tray.



RISK OF FIRE!

- Make sure that there are no inappropriate objects in the appliance before use (i.e. instruction booklets, plastic bags, etc...) or cleaner residuals.
- **Do not place sources of heat (i.e. grills, fryers, etc.), highly flammable substances or fuels in the vicinity of the appliance (i.e. gasoline, petrol, bottles of alcohol, etc...).**
- Always keep the prover cavity clean, performing daily cleaning or after each use: fats or food residue left inside the appliance could ignite!



RISK OR ELECTRICAL SHOCK

- Do not open the compartments marked with these symbols: access is reserved to qualified personnel authorised by UNOX.
- Failure to observe these regulations may cause damage and fatal injuries, and also invalidates the guarantee.



INSTRUCTIONS FOR THE INSTALLER



Contents

| | |
|--|-------|
| Unpacking | 7 |
| Removing the protective film | 9 |
| Checking package contents | 9 |
| Positioning | 10 |
| Characteristics of the installation area | 10 |
| Appliance distances | 11 |
| Positioning for models XEBPC-16EU-M e XEBPC-16EU-D | 12 |
| Positioning for models XEBPL-16EU-M e XEBPL-16EU-D | 14 |
| Levelling the appliance | 12-14 |
| Adjustments | 16 |
| Door closure adjustment | 16 |
| Electrical connections | 17 |
| Checks | 18 |
| Plumbing connections | 18 |
| Plumbing: water supply | 18 |
| Water supply: specifications | 18 |
| Plumbing: water drainage | 20 |
| Drainage specifications | 20 |
| Plumbing: interventions | 20 |



Before installing the appliance carefully read chapter "Safety regulations" on page 4 and the chapter "Forward" on page 4.

During installation, wear proper protective clothing (protective footwear, gloves, etc.).

Unpacking



Persons necessary
for installation:

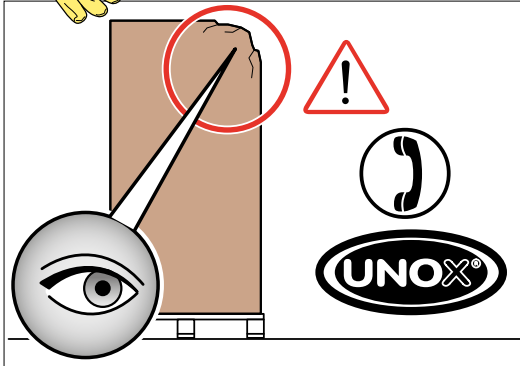

Check the package for any visible damage. If damage is found, promptly contact UNOX and DO NOT install the appliance.

Before transporting the appliance to its installation point, make sure that:

- it easily passes through doorways;
- the floor supports its weight.

Transport must be exclusively performed by mechanical means (i.e. transpallet lifter).

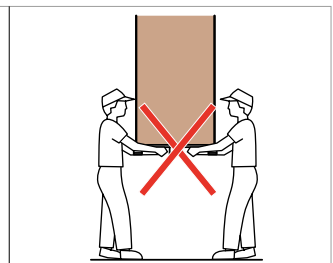
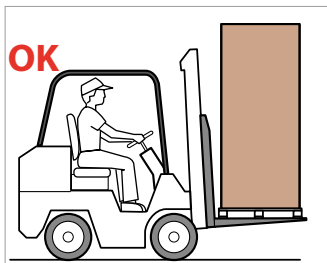
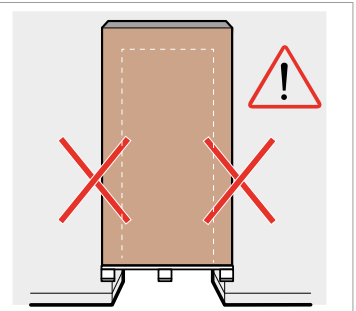
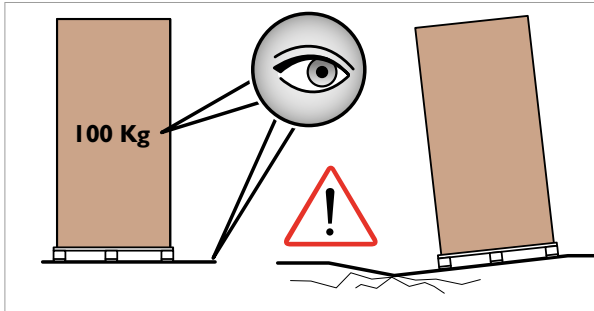

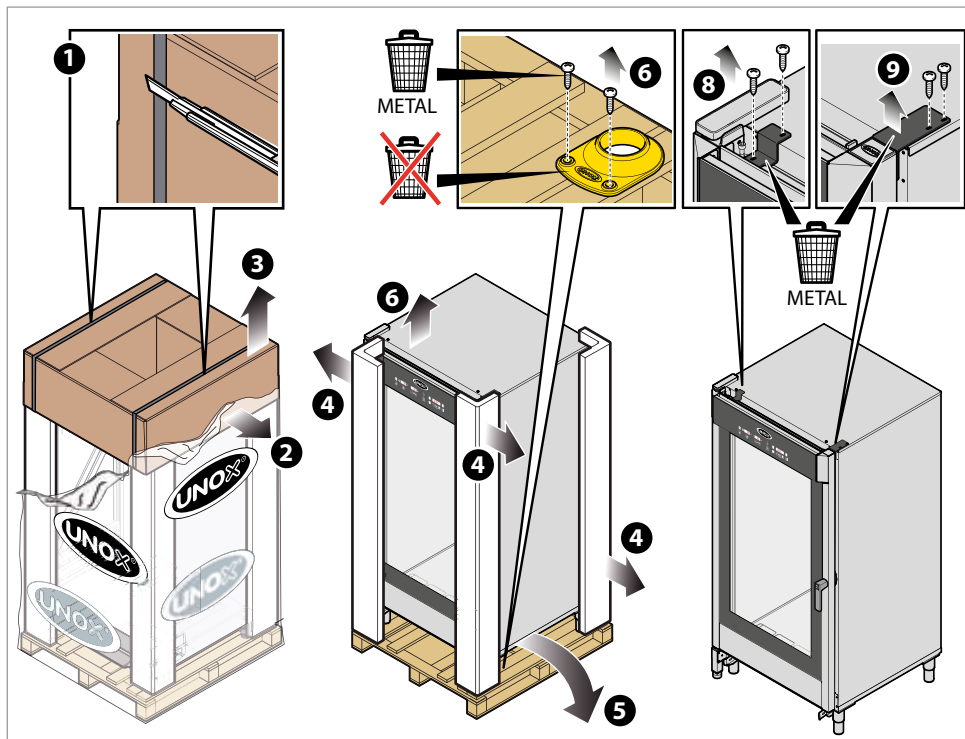

Given their potential danger, the packaging materials must be kept out of reach of children and animals, and correctly disposed of in compliance with local regulations.

UNOX has followed the **NON-STOP Efforts** philosophy for years to increase the environmental compatibility of its products to reduce energy consumption and wastes.

UNOX wishes to protect the environment and invites the consumer to dispose of waste in recycling bins.

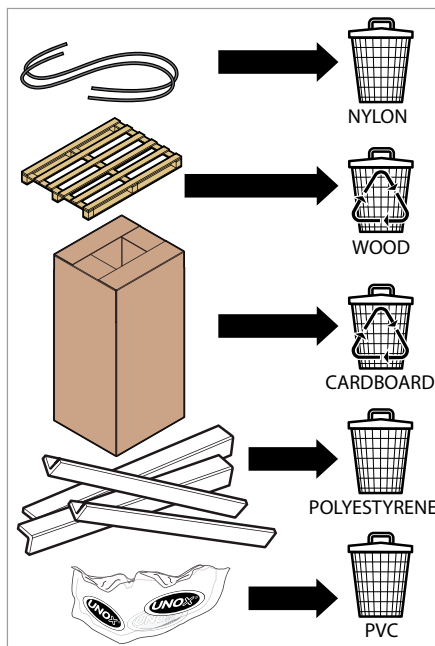

Removing the protective film

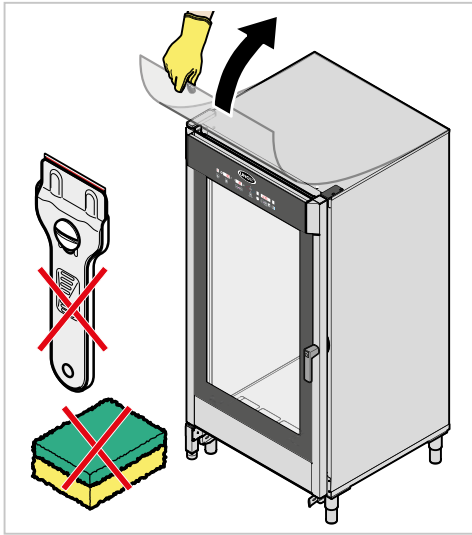

Slowly remove the protective films from the appliance: clean any glue residue with appropriate solvents without using tools, abrasive detergents or acids that could ruin the surfaces.



The removed film, given its potential danger, must be kept out of reach of children and animals; and correctly disposed of in compliance with local regulations.

Checking package contents

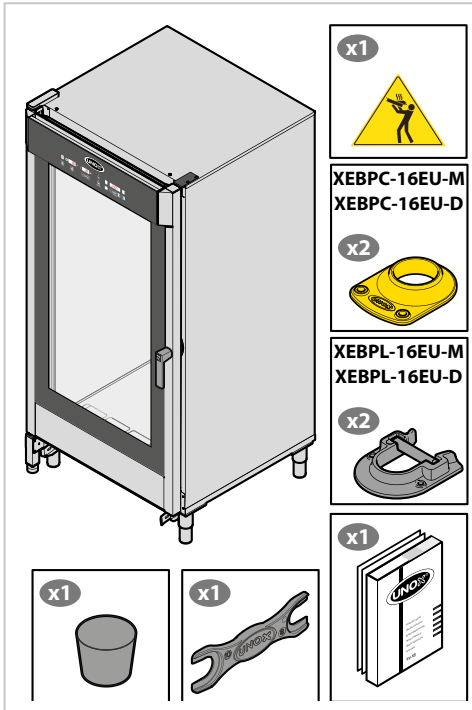

Before installing the appliance, check that the following packaged components are present and free of damage:

- prover with rear side ready for:
 - electrical connections (power supply cable already assembled);
 - plumbing (water supply tube, mechanical filter, 3/4 fitting with non-return valve already assembled);
- technical documents (use and installation manual, "Technical specifications" sheet);
- 2 plastic floor supports;
- 1 "Starter Kit" bag (1 attachment wrench, 1 falling liquid warning sticker, 1 conical exhaust plug).

Contact UNOX if any pieces are missing.



The appliance does not include the tray-holder trolleys (supplied with the BakerTop™ or BakerLux™ trolley ovens). If you want to purchase another one, contact UNOX for further information.



Positioning

Characteristics of the installation area

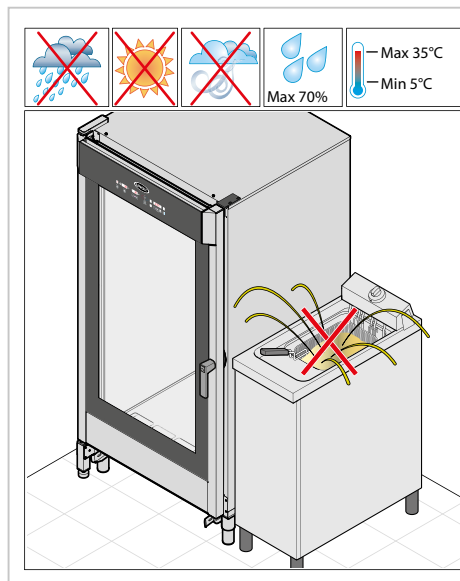

Install the appliance in areas:

- dedicated and conforming to the cooking of industrial foods;
- having adequate air ventilation;
- that comply with the laws in your country;
- protected against the weather;
- with temperatures between +5° to +35°C maximum;
- having a maximum humidity of 70%.

The installation areas must be equipped with electrical and plumbing systems that comply with the regulations on system and work safety of the country of use.



The appliance cannot be installed into a recess
Make sure that the floor supports the weight of the appliance (see "Table A").



For additional technical information on the appliance, consult the "Technical specifications" sheet attached to the appliance.

Table A

| MODELS | Size (LxWxH) | Weight kg | Voltage V | Frequency Hz | Power kW |
|-------------------------------|------------------|--------------|--------------|-----------------|-------------|
| XL1003 - Manual | 866x950x1879 mm | 150 kg | 220-240V~1N | 50/60 | 2,4 |
| XL1005 - Dynamic | 866x950x1879 mm | 150 kg | 220-240V~1N | 50/60 | 2,4 |
| XEBPC-16EU-M - Manual | 882x965x1861 mm | 150 kg | 220-240V~1N | 50/60 | 2,4 |
| XEBPC-16EU-D - Dynamic | 866x974x1875 mm | 150 kg | 220-240V~1N | 50/60 | 2,4 |
| XEBPL-16EU-M - Manual | 882x1015x1874 mm | 151 kg | 220-240V~1N | 50/60 | 2,4 |
| XEBPL-16EU-D - Dynamic | 882x974x1891 mm | 147 kg | 220-240V~1N | 50/60 | 2,4 |

Appliance distances

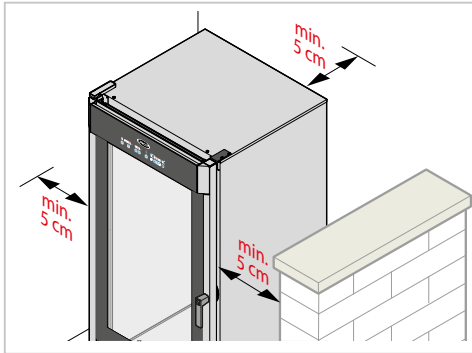

Position the appliance respecting the indicated distances in the diagram and so that the back of the oven is easily accessible for appliance connections and maintenance.



Do not install the appliance near flammable or heat sensitive materials, walls or furniture. Otherwise, protect them with appropriate non-flammable materials in compliance with fire prevention regulations - see diagram below.

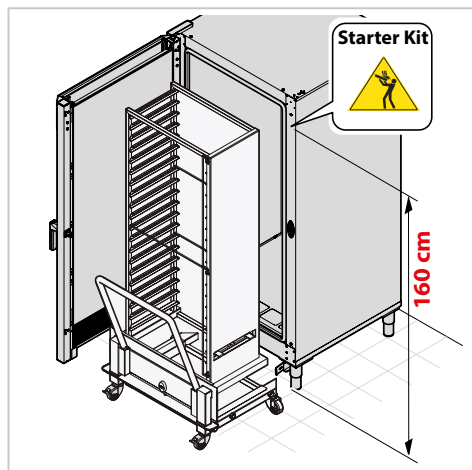
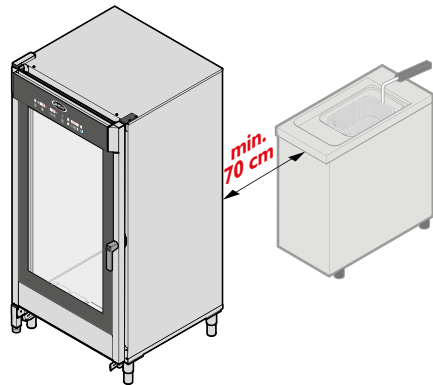
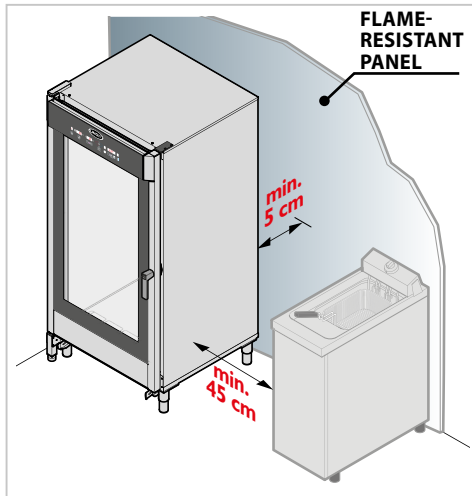

For safety reasons, the last tray should NEVER be placed at a height greater than 160 cm.

If necessary to do so, **it is mandatory to post the sticker contained in the "Starter Kit" at the height shown in the figure.**



Positioning for models XEBPC-16EU-M e XEBPC-16EU-D

Provers must exclusively be set on floors that meet the following requirements:

- be flame and heat resistant;
- be perfectly level;
- have a flat and even surface;
- able to support the appliance weight at full load without undergoing deformation or structural failure.

Levelling the appliance

Check that the length of the prover cavity diagonals are the same **1**.

If it is not the same, it means that the appliance is not perfectly levelled **2** -> level it by adjusting the height of the 4 legs: to allow for an easy insertion of the trolley, the minimum height from the ground must not be less than 17.3 cm **3**.

Once level, check:

- that the trolley easily enters into the oven cavity without encountering obstacles (e.g. floor irregularity) and without brushing against the bottom surface of the prover cavity **4**; further adjust the feet if necessary.
- that the support base of the door touches the floor, otherwise turn it to adjust its height **5**.



Finish by **compulsorily anchoring the 2 front supports to the floor to avoid capsizing** (see figure on the following page).

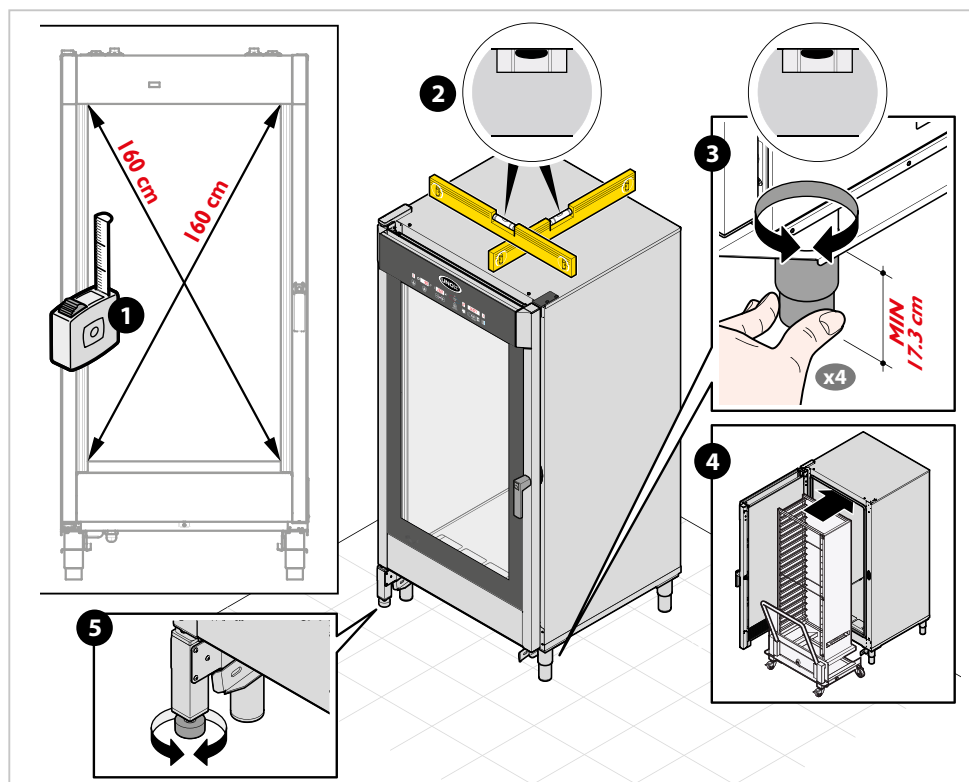

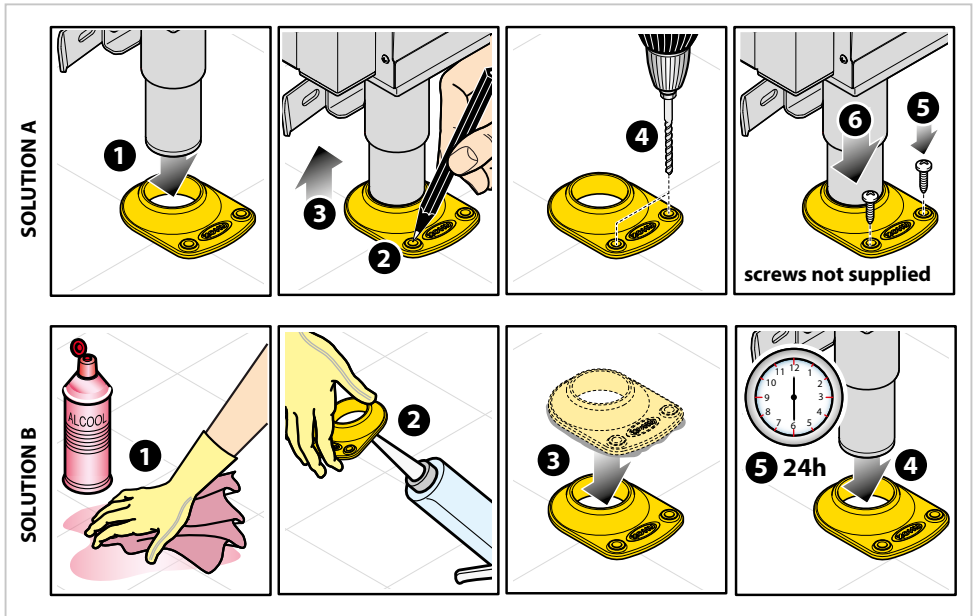

If the floor is not perfectly flush, use a loading ramp with a maximum incline of 4°. The maximum floor incline allowed is 2°.

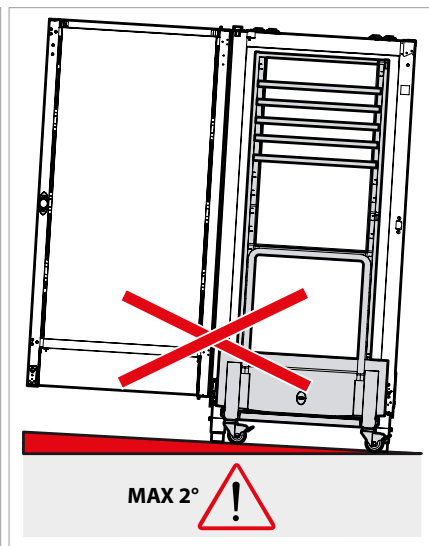
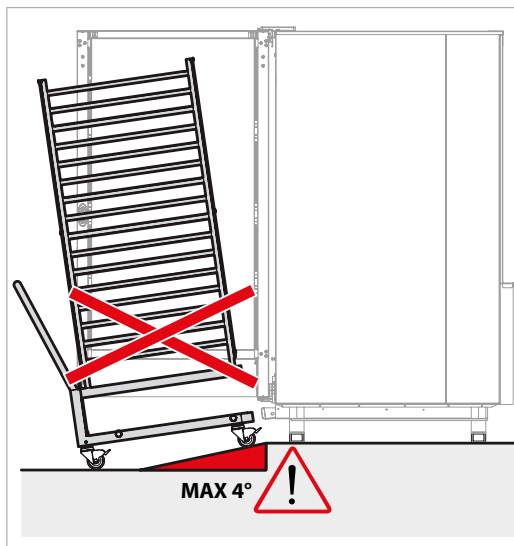



Positioning for models XEBPL-16EU-M e XEBPL-16EU-D

Provers must exclusively be set on floors that meet the following requirements:

- be flame and heat resistant;
- be perfectly level;
- have a flat and even surface;
- able to support the appliance weight at full load without undergoing deformation or structural failure.

Levelling the appliance

Check that the length of the prover cavity diagonals are the same **1**.

If it is not the same, it means that the appliance is not perfectly levelled **2** -> level it by adjusting the height of the 4 legs: to allow for an easy insertion of the trolley, the minimum height from the ground must not be less than 19 cm **3**.

Once level, check:

- that the trolley easily enters into the oven cavity without encountering obstacles (e.g. floor irregularity) and without brushing against the bottom surface of the prover cavity **4**; further adjust the feet if necessary.
- that the support base of the door touches the floor, otherwise turn it to adjust its height **5**.



Finish by **compulsorily** anchoring the 2 front supports to the floor to avoid capsizing (see figure on the following page).

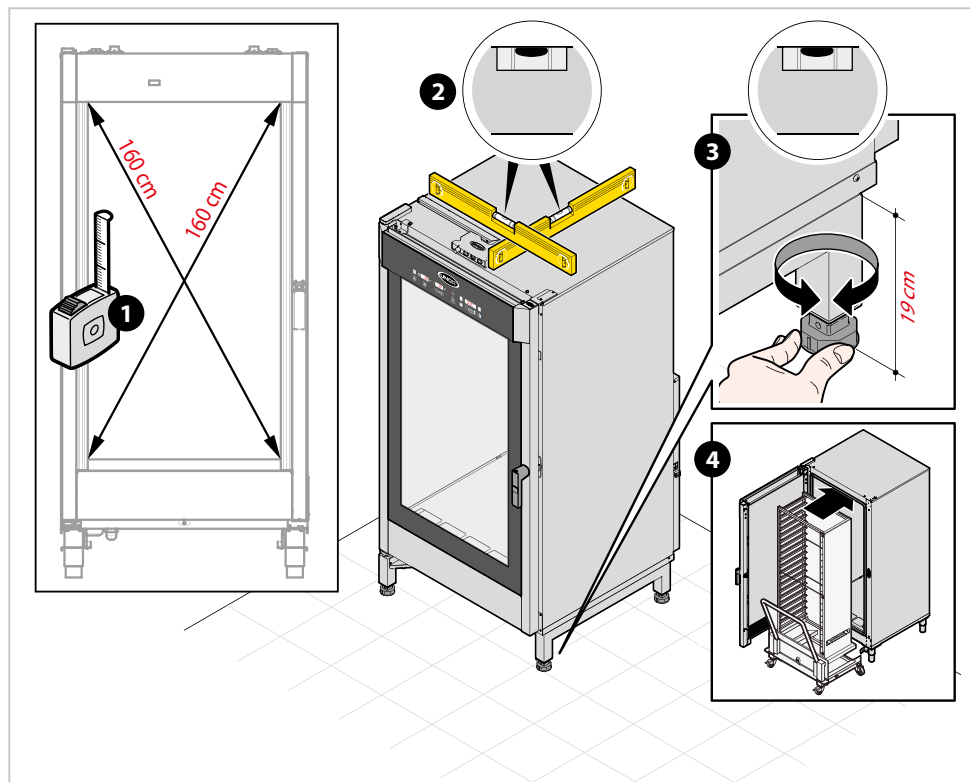

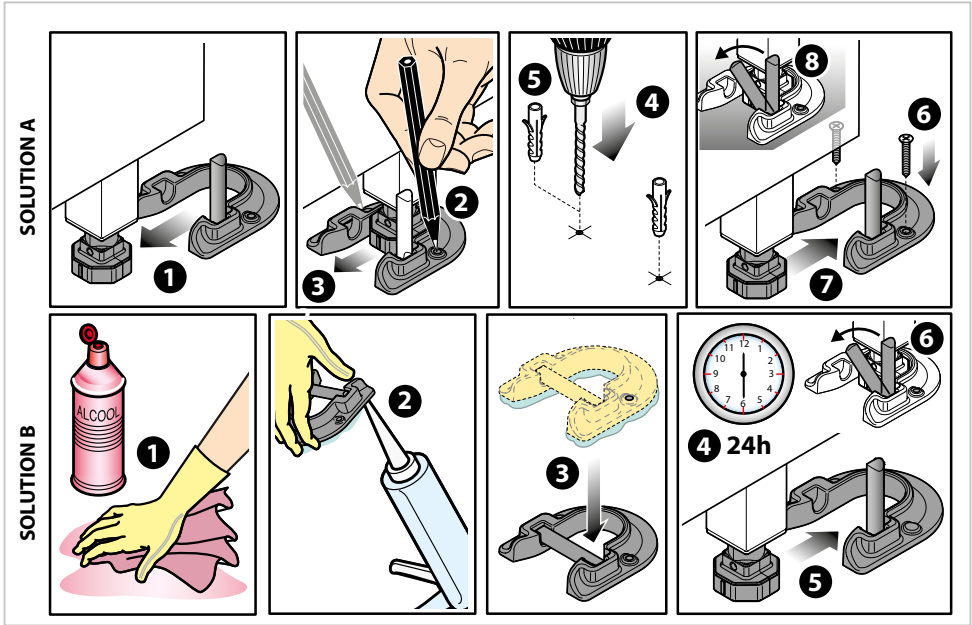

If the floor is not perfectly flush, use a loading ramp **with a maximum incline of 4°**. The maximum floor incline allowed is **2°**.

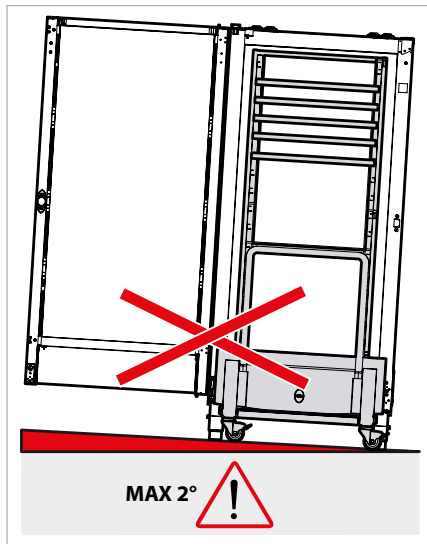
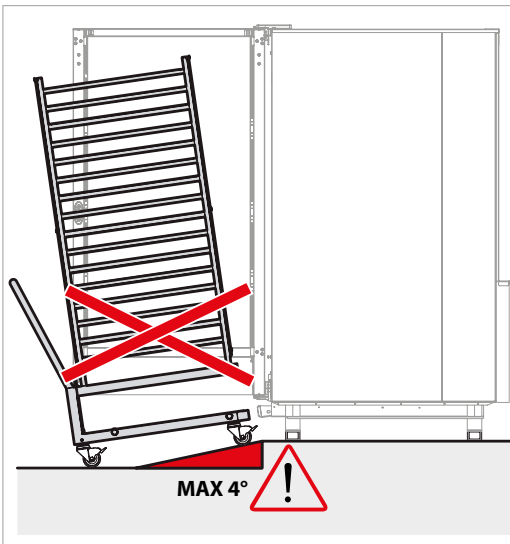



Adjustments

Door closure adjustment

After positioning the prover, proceed as follows if the door handle fails to close in the correct upright position:

- 1 check that the appliance is flush by using a spirit or digital level;
- 2-7 if the appliance is level, adjust the closure latch as shown in the following figures.
If the problem persists, repeat this procedure, loosening the latch fixing screws further.

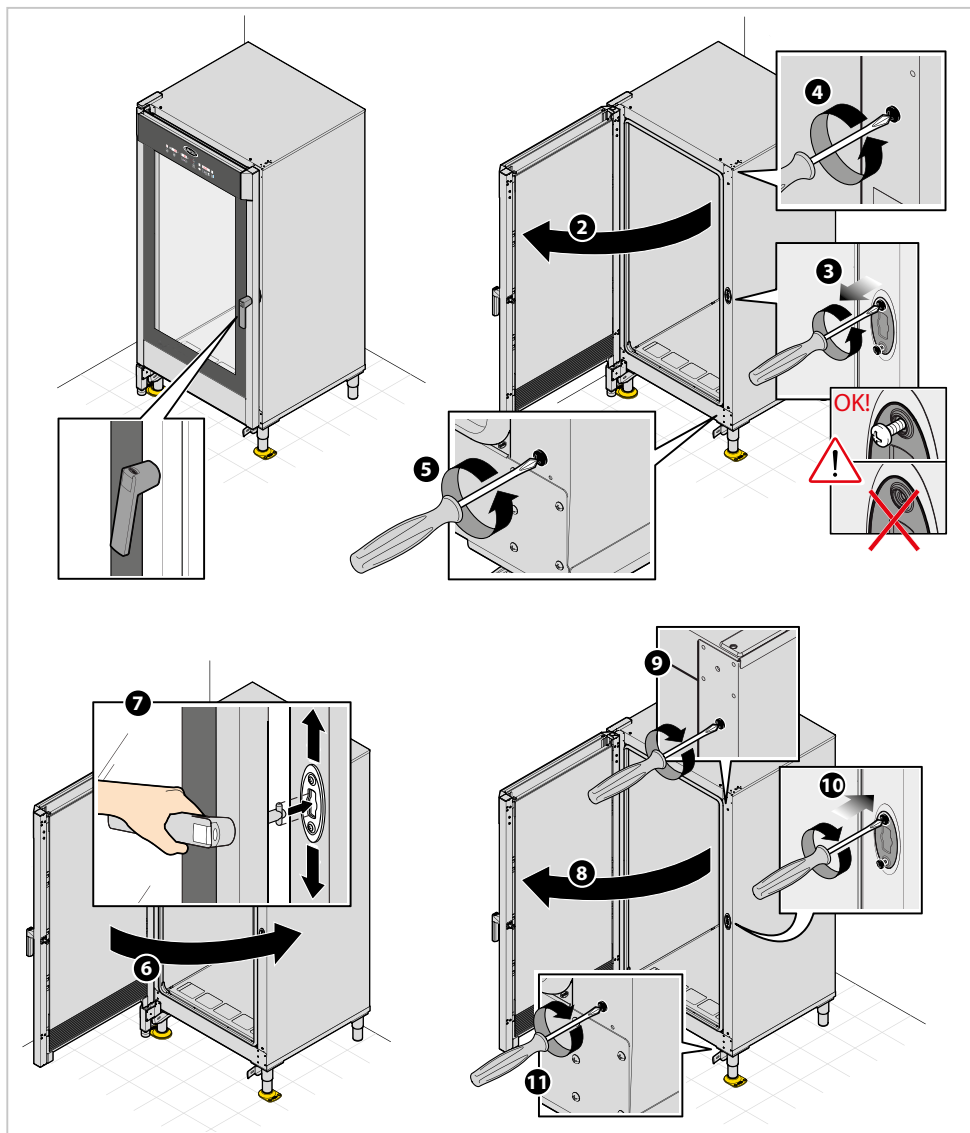

Electrical connections



Before installing the appliance carefully read chapter “Safety regulations” on page 4.



Connections to the power main and the electrical system must comply with the regulations in force in the country of installation of the appliance; and all connections must be performed by qualified personnel authorised by UNOX. Failure to comply with these regulations may cause damage and injuries, invalidates the guarantee and relieves UNOX of all liabilities.



Before connecting the appliance to the electricity mains, always compare the power supply data with that of the appliance specified on the rating plate.

The appliance has its power cable already factory mounted to the terminal board; may **not** undergo any other type of electrical connection and no dimensional modification of the cable other than extensions, replacing it only with one having specifications equal to the original factory cable (type of rubber, cross-section, etc.)



The cable must be replaced by UNOX or by its technical assistance service, and in all cases by a person with similar qualification in order to avoid possible risks.



The wiring diagrams, wire specifications and the technical data are indicated on the “Technical specifications” sheet attached to the appliance.

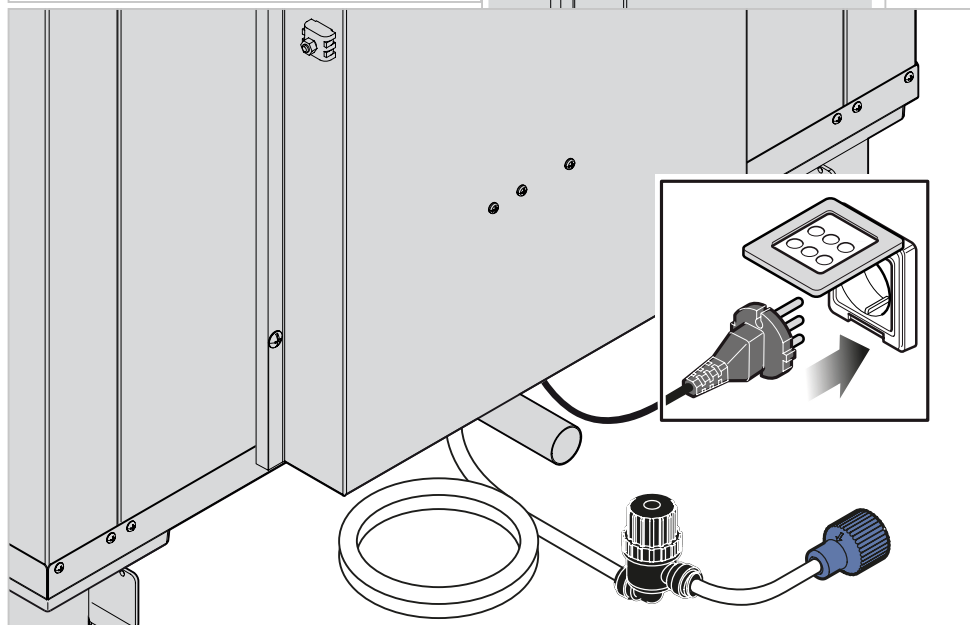

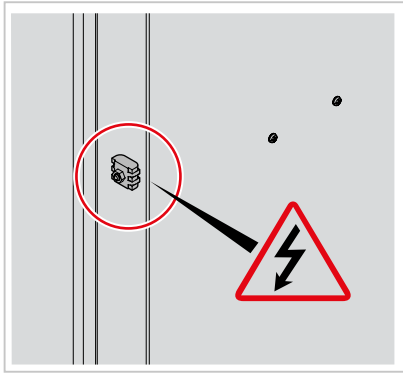

For proper electrical connections, the appliance must:

- Be wired into an equipotential system in accordance with current regulations. This connection must be performed between different appliances with the terminal marked with the equipotential symbol .

The cable must have a maximum cross-section of 10 mm² (pursuant standard CEI EN 60335-2-42:2003-09) and be of yellow-green colour.

- Must be grounded  to the earthing (green-yellow wire).
- Must be connected to a thermal differential switch in compliance with the regulations in force.
- Must be connected to an omnipolar circuit breaker.

Checks

- The copper jumper and the electrical cable must be secured together beneath the screw in its tightening direction; and the electrical connections must be well secured before connecting the appliance to the electricity mains.
- Check for any electrical dispersion between the phases and the ground, and for electrical continuity between the external casing and the main ground line.
- Check that the power supply voltage does not deviate from the nominal voltage value specified on the appliance rating plate when the appliance is operating.

Plumbing connections

Plumbing: water supply

The rear of the appliance contains: 1.5 meters of hose, mechanical filter and (3/4") fitting with non-return valve for plumbing. Before connecting the water pipe to the appliance, flush it out with water in order to eliminate any residue which has accumulated inside it. A shut-off valve should be positioned between the water mains and the appliance.

Water supply: specifications

Inlet water must have the following specifications:

- maximum water temperature of 30 °C;
- drinking water;
- water pressure between 150 and 600 kPa (we recommend 200 kPa).



The inlet water must not contain chloramine, or chloramine levels higher than 0.1 ppm (mg/L).
Warning: damage caused by an excess of chloramine is not covered by warranty.

Indicator for the evaluation of the probability of corrosion

Formula: $NHM = EC - (TH^{**} \times 30)$

EC = electrical conductivity [$\mu S/cm$]

TH = total hardness** [$^{\circ} dH$ - German degrees]

Maximum chloride content, Cl-; this is not a fixed value, but depends on the NHM (Non Hardness Measurement) calculated value

| | | |
|-----------------------|--|--------------------|
| NHM ≤ 250 µS/cm | TH < 8 °dH, Cl- ≤ 25 ppm (5 drops of reagent*) | No water treatment |
| | TH ≥ 8 °dH, Cl- ≤ 25 ppm (5 drops of reagent*) | UNOX.Pure |
| | Cl- > 25 ppm (5 drops of reagent*) | UNOX.Pure-RO |
| NHM = 250 - 350 µS/cm | Cl- ≤ 20 ppm (4 drops of reagent*) | UNOX.Pure |
| | Cl- > 20 ppm (4 drops of reagent*) | UNOX.Pure-RO |
| NHM = 350 - 450 µS/cm | Cl- ≤ 15 ppm (3 drops of reagent*) | UNOX.Pure |
| | Cl- > 15 ppm (3 drops of reagent*) | UNOX.Pure-RO |
| NHM = 450 - 500 µS/cm | Cl- ≤ 10 ppm (2 drops of reagent*) | UNOX.Pure |
| | Cl- > 10 ppm (2 drops of reagent*) | UNOX.Pure-RO |
| NHM ≥ 500 µS/cm | | UNOX.Pure-RO |

* use the UNOX KSTR1081A Kit reagent

** hardness measured with the UNOX KSTR1082A kit

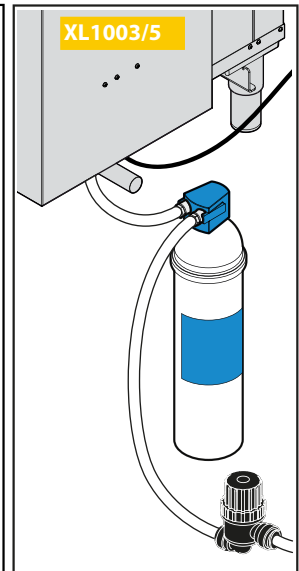
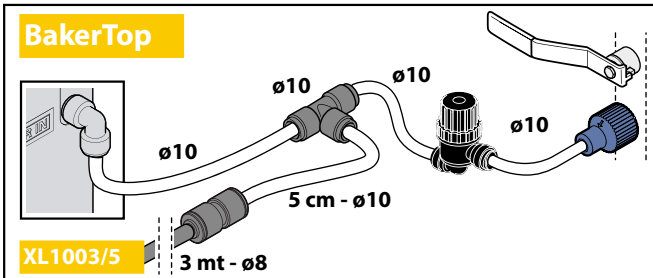
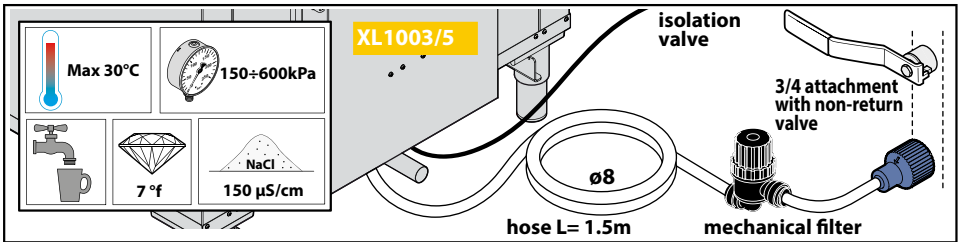

The new hose-sets supplied with the appliance are to be used for the connection to the water supply network. Old hose-sets should not be reused.



Plumbing: water drainage

The drain is located on the rear of the appliance: connect it to a syphon (not provided) and connect it to a waste water drain. UNOX recommends using its syphons.

Drainage specifications

The drainage system must:

- be a siphon-type;
- have a one meter maximum length;
- have a minimum incline of 4%;
- have a diameter that is NOT less than the drain pipe attachment;
- be dedicated to each appliance; if this is not the case, make sure that the main drainage pipe is sized sufficiently to ensure that water flows away properly without any problems;
- be free of kinks.
- The wall-mounted exhaust output must have an air gap of at least 25 mm.

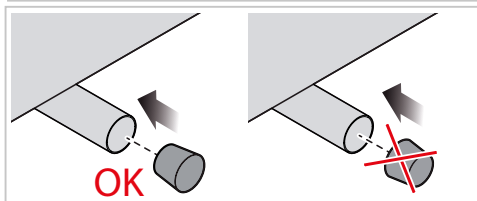
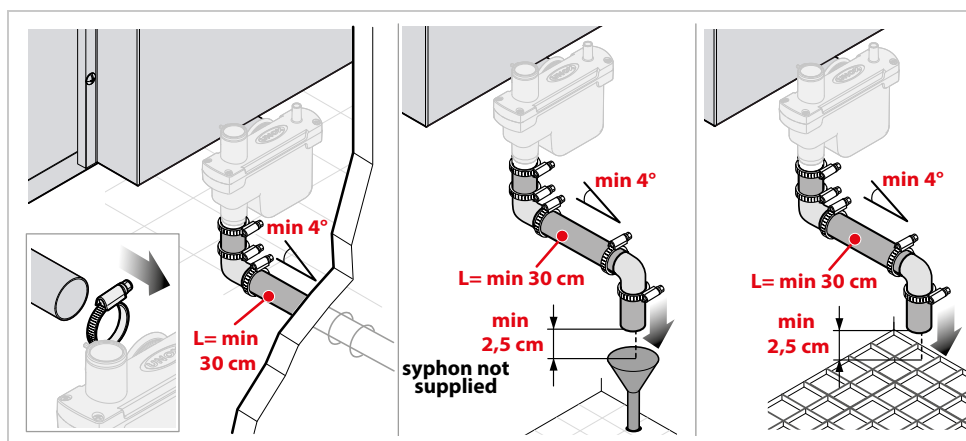

If the appliance cannot be permanently connected to a drainage system, the drainage terminal must be sealed with the conical plug supplied inside the "Starter kit".

Make sure that it is easy to reach the back of the prover in order to frequently inspect and clean the drainage terminal.

Plumbing: interventions

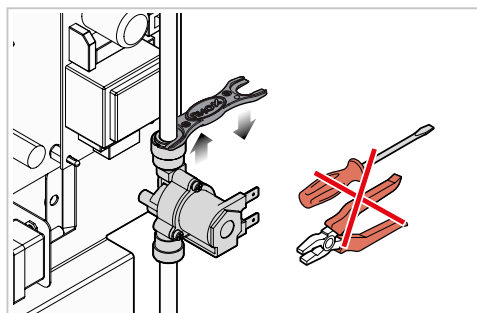

If it is necessary to disconnect the "quick coupling" attachments, for maintenance or to install an accessory, use the spanner supplied in the "Starter Kit": using other tools (i.e. screwdrivers, pliers, etc...) could damage the part and compromise the seal.



INSTRUCTIONS FOR THE USER

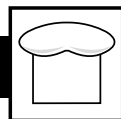

Contents

| | |
|---|----|
| General appliance operating instructions | 22 |
| Loading and using the trolleys | 23 |
| Presentation of the appliance | 24 |
| Using mod. XL1003 - XEBPC-16EU-M - XEBPL-16EU-M <i>Manual</i> | 25 |
| Using mod. XL1005 - XEBPC-16EU-D - XEBPL-16EU-D <i>Dynamic</i> | 26 |
| Control panel | 26 |
| Basic notions | 27 |
| MANUAL mode | 28 |
| PROGRAMMED Mode | 30 |
| Oven-user communication (only mod. XL1005 - XEBPC-16EU-D - XEBPL-16EU-D <i>Dynamic</i>) | 34 |
| Routine maintenance | 35 |
| External steel structures, prover cavity seal | 35 |
| Internal door window | 35 |
| Plastic surfaces and control panel | 35 |
| Prover cavity | 36 |
| Inside and outside oven door window glass | 36 |
| Cleaning the spray nozzle (only models XL1005 - XEBPC-16EU-D - XEBPL-16EU-D <i>Dynamic</i>) | 36 |
| Inactivity | 37 |
| Disposal | 37 |
| After-sales assistance | 38 |
| Certification | 39 |
| Guarantee | 39 |



INSTRUCTIONS FOR THE USER



Before using the appliance:

- make sure that you have a system conformity and use permit certificate that is issued by a UNOX authorised installer;
- carefully read the chapter "Safety regulations" on page 4 and the chapter "Forward" on page 4.

General appliance operating instructions

- when using the appliance for the first time be sure to thoroughly clean the inside of the prover cavity and the accessories (see chap. "Routine maintenance" at page 35); let the oven run empty at maximum temperature for 1 hour to eliminate any unpleasant odours caused by protective factory grease.
- Operate the appliance at a room temperature between +5°C and +35°C.
- Maximum tray weight allowed is 5 Kg; heavier loads damage the lateral metal guides and trays.
- Do not hang or lean up against the door of the prover.
- Use the UNOX grills and trays attempting to arrange the food evenly on them, avoiding overlapping of food or over loading them.
- Always respect your appliance's load capacity.
- To avoid scalding, do not use loaded containers with liquids or cooking goods which becomes fluid by heating in higher levels than those which can be easily observed.

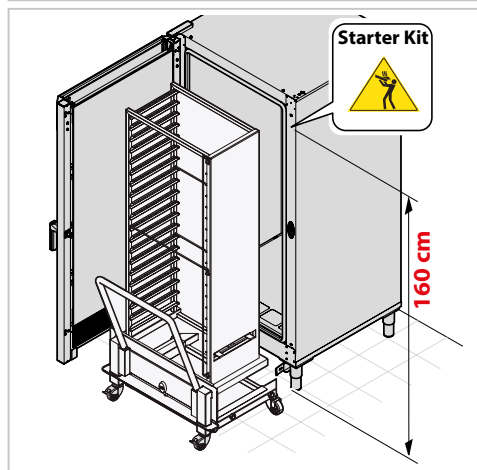
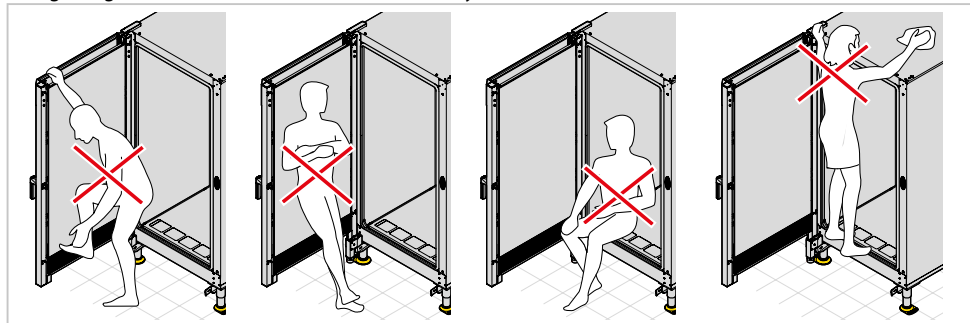

For safety reasons, the last tray should NEVER be placed at a height greater than 160 cm.

If necessary to do so, **it is mandatory to post the sticker contained in the "Starter Kit" at the height shown in the figure.**

Loading and using the trolleys

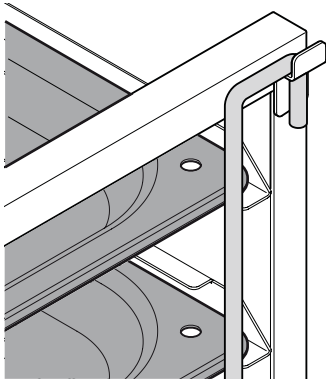
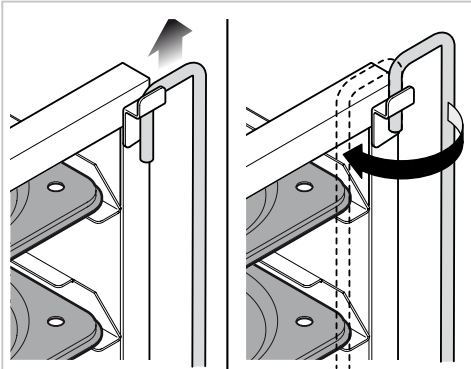

Use only UNOX trolleys, trays and grills.



The appliance does not include the tray-holder trolley (supplied with the **BakerTop™** or **BakerLux™** trolley ovens).

If you want to purchase another one, contact UNOX for further information.

- Load the trolleys without overloading them: it is normal for the trolley to be pushed downward and lower in height, depending on how full the trays are.
- The trolley is loaded into the prover using the bottom trolley guides.
- Lock the trays into place when moving the trolley as shown in the figure.
- Always lock the front wheel brakes into place after putting loads into the prover cavity and each time these are not to be moved.
- Be very careful when handling because the trolleys can tip over (e.g. transporting them on uneven surfaces, slopes or through the doors).

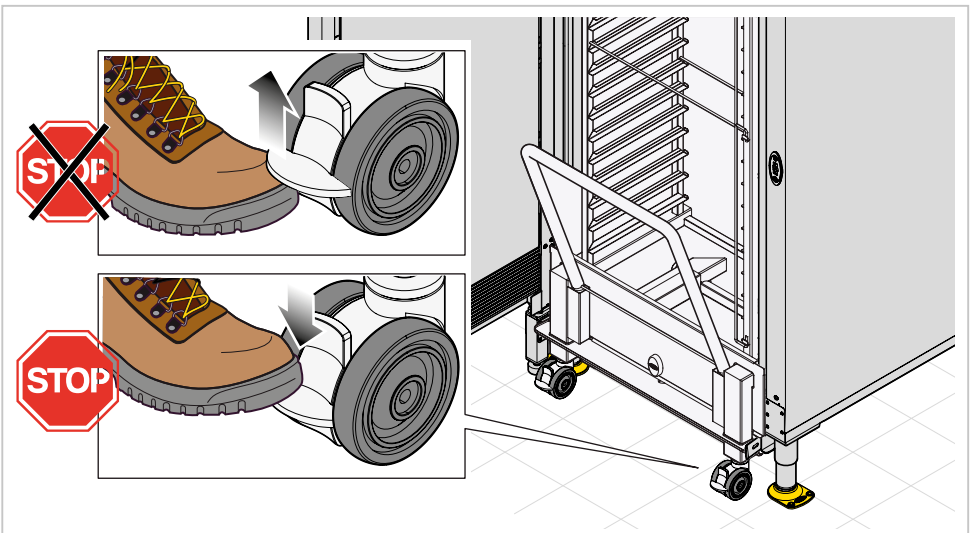



Presentation of the appliance

Manual

WATER COLLECTION TANK WITH LID TO GENERATE HUMIDITY

DOOR WITH INTERNAL WINDOW GLASS THAT CAN BE OPENED AND POSITIONED AT 60°-120°-180°

DOOR REINFORCEMENT BRACKET

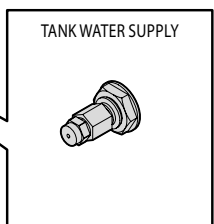
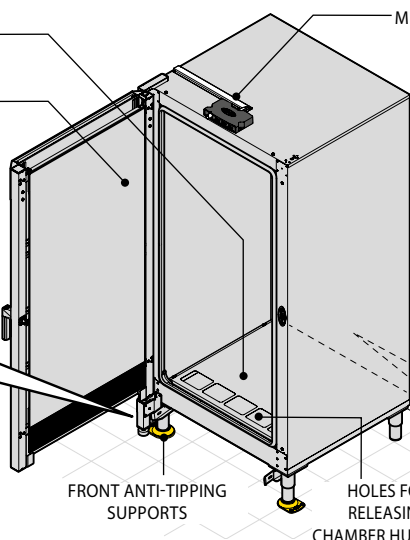
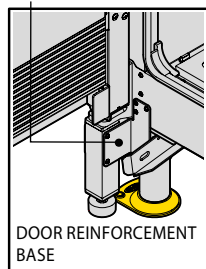

Dynamic

WATER COLLECTION TANK WITH LID TO GENERATE HUMIDITY

DOOR WITH INTERNAL WINDOW GLASS THAT CAN BE OPENED AND POSITIONED AT 60°-120°-180°

DOOR REINFORCEMENT BRACKET

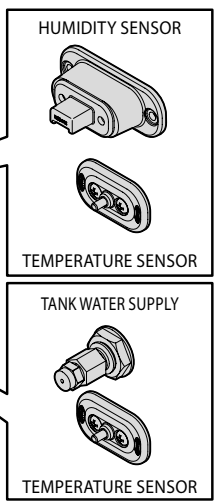
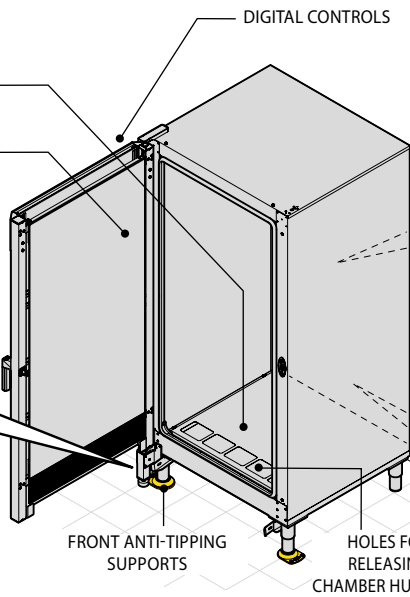
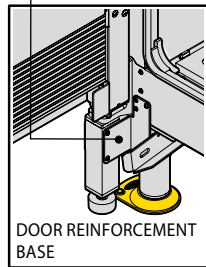

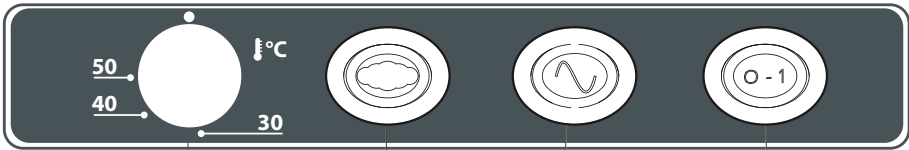
Using mod. XL1003 - XEBPC-16EU-M - XEBPL-16EU-M *Manual*

Turn the knob to set the temperature in the prover cavity (range from 30 to 50°C)

Press the button to input humidity into the prover cavity

LIGHT on - appliance on

Push the "0-1" switch to turn the appliance on and off

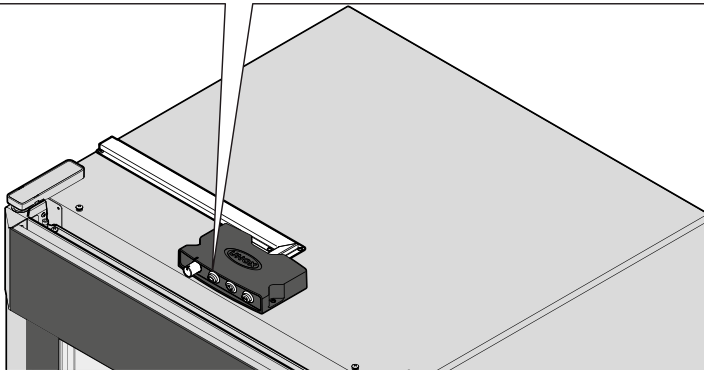



Using mod. XL1005 - XEBPC-16EU-D - XEBPL-16EU-D *Dynamic*

The prover control panel is used by pressing the screen-printed keypad.

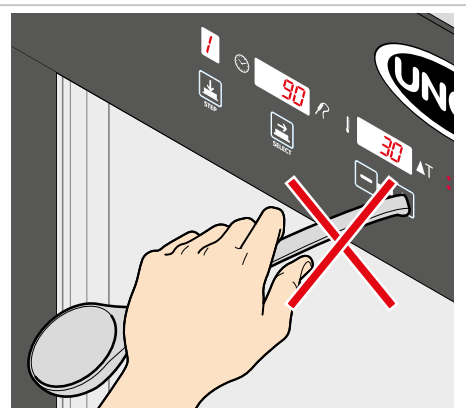

Press only with fingers and no other objects, such as knives, forks, etc...

This technology makes cleaning the control panel quick and easy, while guaranteeing maximum reliability and durability and avoiding any type of mechanical failure.

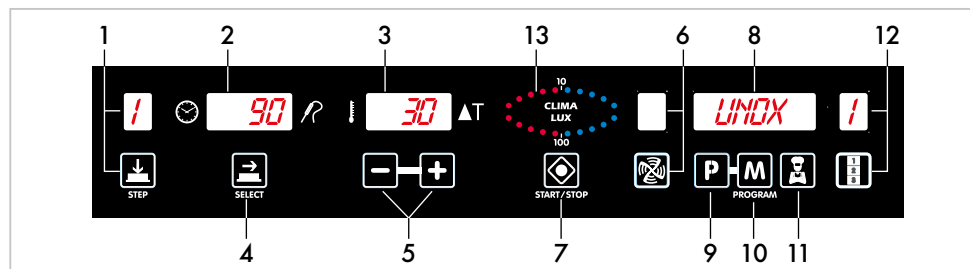

Control panel



- 1) Press repeatedly to select the 9 STEPS: the screen displays the STEP in use.
- 2) Proving duration viewing display.
- 3) Temperature in prover cavity viewing display.
- 4) Press the button repeatedly to select the parameters to set (temperature, cooking duration, humidity).
The active parameter is indicated by the blinking corresponding icon:
 proving time shown on screen as hours: minutes
 cavity probe temperature shown on screen as °C
- 5) Increases/decreases values shown on screen.
- 6) Manually feeds humidity in the chamber
- 7) Switches on the appliances, starts/stops the leaving cycle. The lit icon means that the prover is on.
- 8) Programming screen.
- 9) Programming button (for details see page **30**)
- 10) Saves set programs.
- 11) Allows access to the PURE feature
- 12) Allows updating of the software (refer to the manual code LI2354A UNOX.LINK)
- 13) **CLIMA LUX** - With consecutive presses on the right, controls the steam input (**STEAM. Maxi™**).

Basic notions

The appliances can be used in **MANUAL** or **PROGRAMMED** mode.

The **MANUAL** mode implies that the following parameters for each leavening cycle are set by the user:

- leavening time;
 - oven cavity temperature;
 - percentage of humidity released in the chamber - **STEAM.Maxi™**;
- The parameters set are NOT saved and must be entered during each successive use.

PROGRAMMED mode makes it possible to:



- save, with a user given name (up to 50 letters), up to 20 leavening cycles (programmes) for use in successive leavening sessions;
- use special functions (resume, etc.)

Each leavening cycle comprises **10** steps:

- **STEPS 1...9**: up to 9 leavening steps, each characterized by different leavening parameters. Leavening does not necessarily require all nine STEPS: set only those required. The appliance automatically passes from one leavening phase to the next.

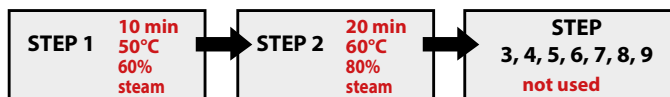
Ex. LEAVENING CYCLE



- When the prover is connected to the power supply, the control panel switches on automatically.
- Button functions  :
 - single repeated pressing -> increases/decreases the value one unit at a time;
 - held down -> increases/decreases the value rapidly.
- If none of the buttons are pushed for 15 minutes, the electronic control goes into standby: only the START/STOP LEDs remain on. Simply press the START/STOP button to reactivate the electronic controls.





If the oven's sound signal is too low, UNOX recommends installing its Buzzer kit to increase the volume; the kit can be installed at any moment by a specialised technician.

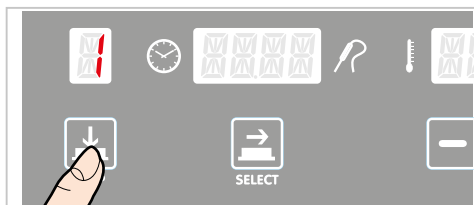

MANUAL mode

STEP SELECTION



- 1 Press the  button;
- 2 the number of the STEP in use appears on screen "1" (up to a maximum of 9 STEPS).

SETTING THE LEAVENING DURATION

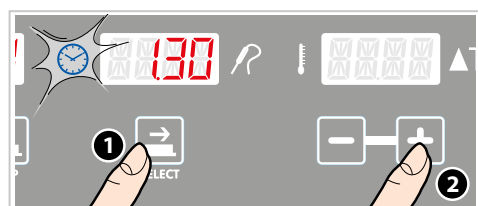





"INF"/"HOLD" ←  0.00  → 9.59

CONTINUOUS OPERATION MINIMUM DURATION MAXIMUM DURATION

"INF"/"HOLD" (Continuous mode)

The prover is in continuous mode until the user manually intervenes:





- 1 Press the  button repeatedly until the  icon blinks -> **the parameter is active and can be set only when the icon blinks.**
- 2 Set the desired value by pressing the   buttons.
The input values are shown on screen as hours, minutes (time setting)

SETTING PROVER TEMPERATURE



50°C ←  0°C  → 50°C

MAXIMUM TEMPERATURE MINIMUM TEMPERATURE MAXIMUM TEMP.

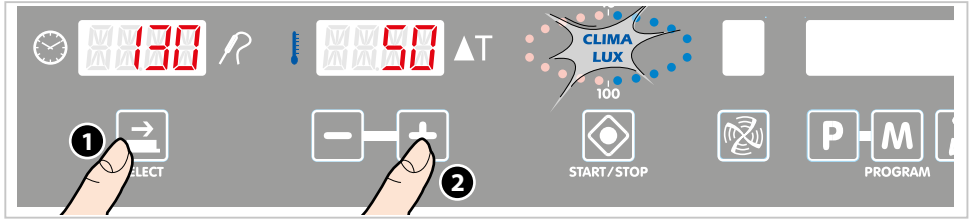

- 1 Press the  button repeatedly until the  icon blinks -> **the parameter is active and can be set only when the icon blinks.**
- 2 Set the desired value by pressing the   buttons.
The input values are shown on screen as °C.

SETTING HUMIDITY (STEAM.Maxi™)





The setting of the humidity within the oven cavity is indicated by the **CLIMA LUX** ellipse and is set using the **-** **+** buttons.

The 10 BLUE LEDs indicate the percentage of target humidity inside the oven cavity (**STEAM.Maxi™**).

- 1 Repeatedly press the  button until the "CLIMALUX" message blinks -> **the parameter is active and can be set only if the message blinks.**
- 2 To INPUT steam into the cavity (**STEAM.maxi**) press the  button repeatedly until setting the desired humidity (BLUE LEDs - from 10% to 100%).

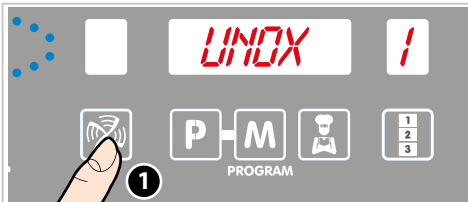
MANUALLY SUPPLYING WATER



- 1 Press the  button until hearing the acoustic signal: water is manually added for **50 seconds**. This generates a considerable amount of steam to help leaven bread and similar goods

SELECTING AND SETTING THE NEXT STEPS (OPTIONAL)

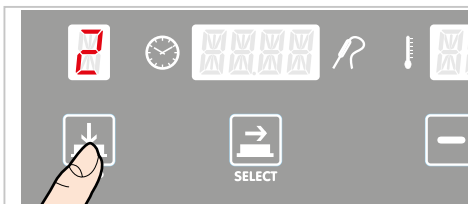

The appliance automatically passes from one STEP to the next.

Cooking does not necessarily require all nine STEPS available: set only those required.
To set step 2:

- 1 press the  button;
- 2 number "2" appears on the screen. Set the various parameters (duration, temperature, etc...) as described in the previous sections. If necessary, select and set the following STEPS in the same manner.



COOKING START/STOP/REPEAT - OVEN SHUT-DOWN

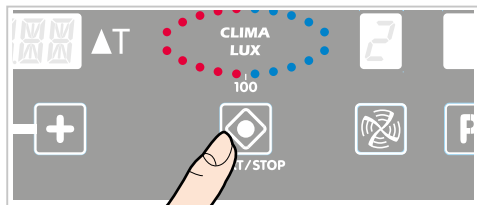

During this time if:

- 1) the button is pressed -> the prover is reactivated with the same parameters set for the previous leaving process.
- 2) the button is pressed -> the prover switches off; the parameters set for the previous leaving process are NOT saved;
- 3) if no button is pressed -> the prover switches off, the parameters set for the previous leaving process are NOT saved

Once the desired leavening parameters have been set, press the button to start the process: press the same button again to stop the process in advance.

Upon completion of leavening, the prover emits an acoustic signal for 15 seconds, the time display blinks and the "START/STOP" LED remains on for 45 seconds.

PROGRAMMED Mode

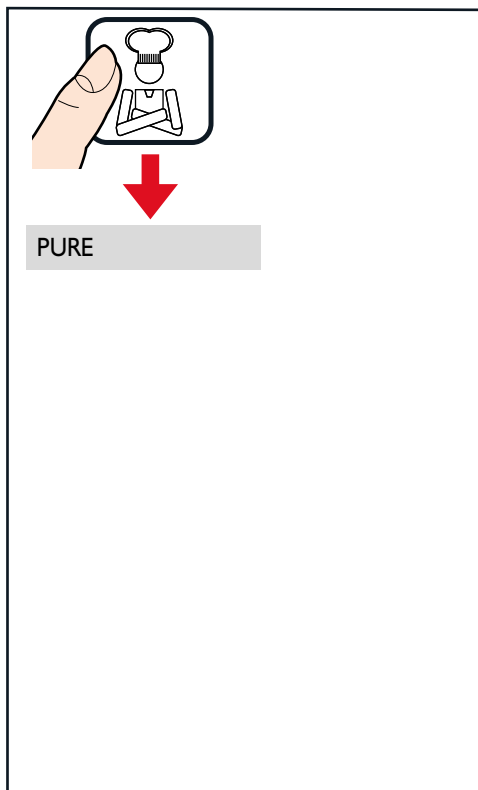
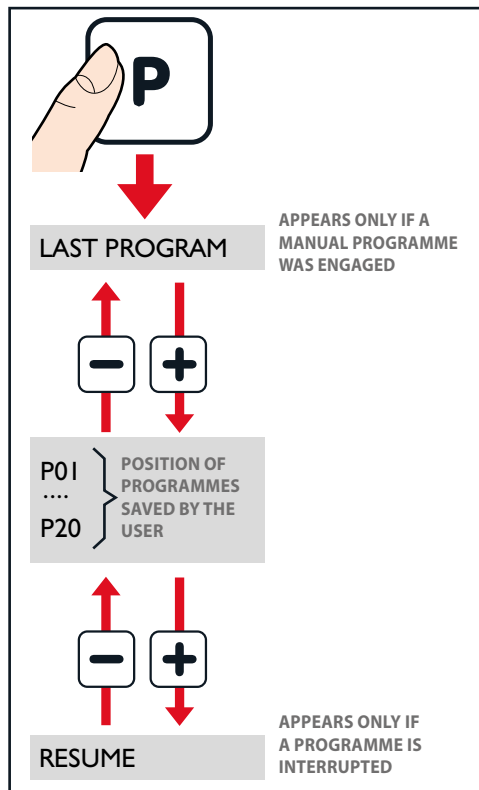

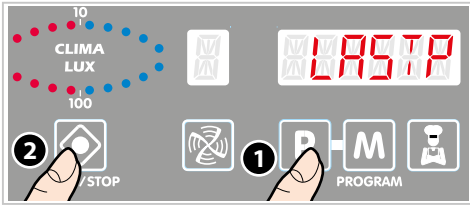
LAST PROGRAM (REPEATS A PREVIOUS LEAVENING CYCLE)

This function fully repeats the last leavening cycle performed (only if performed in manual mode).

- 1 At the end of the leavening cycle, press the **P** button -> screen "8" shows the message "LAST PROGRAM" (or "ULTIMO PROGRAMMA" if Italian is the language set).
- 2 Press the **START/STOP** button -> the last cooking cycle executed starts.

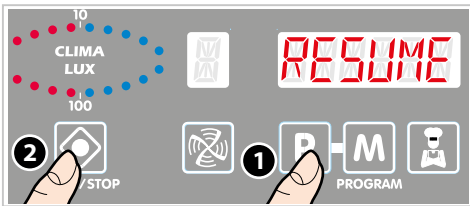
RESUME (RESUMES AN INTERRUPTED COOKING PROCESS)

If a leavening programme was interrupted in advance (executed in manual or programmed modes) this function will restart from the precise stop point while maintaining the same parameters set.

- 1 Press the **P** button until screen "8" shows the message "RESUME" (or "RIPARTI" if Italian is the language set).
- 2 Press the **START/STOP** button: the last leavening cycle executed restarts.

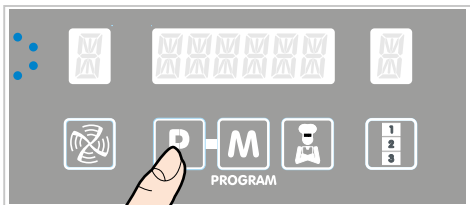
P01->P20 (LEAVENING PROGRAMME SAVE)**Access to the program menu**

Access the programming menu by pressing the button **P**.

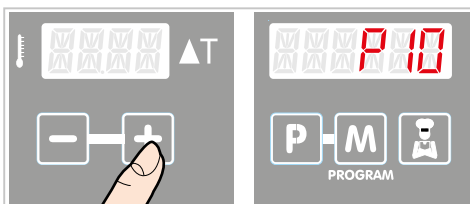
Assigning program position







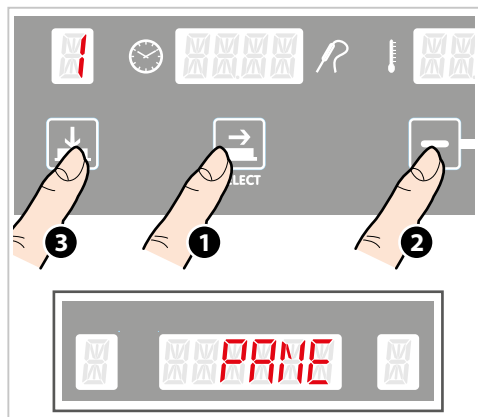

Pressing the **-** **+** buttons repeatedly selects from positions P01 to P20 for programme storage.

The selected position is visualized on screen "8".



Assigning a name to a programme



- 1 Press .
- 2 Use the   buttons to input the 1st letter of the programme name. Press  again and use the   buttons to select the 2nd letter. Repeat the same operation for all successive letters (up to a maximum of 50 letters).
- 3 To end letter input, press the  button and check the name entered:
if correct, press the  button to access the cooking parameters settings;
if incorrect, press the  button to correctly input the letters.

Setting leavening parameters of a program

Set the program parameters as fully explained in the chapter "Manual Operation".





Saving the set program

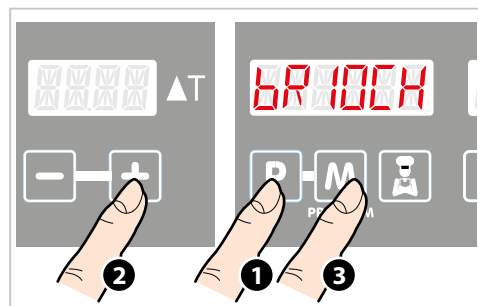

- Hold the  button until hearing the long "beep" sound.
The program has now been saved.

MODIFYING THE PARAMETERS OF A SET PROGRAM



- 1 Press the  button.
- 2 Use the   buttons to call to screen the program to modify.
- 3 Reconfigure the program parameters as fully explained in the chapter "Manual Operation".
- 4 Hold the  button until hearing the long "beep" sound. Now the modified parameters have been saved.

MODIFYING THE PARAMETERS OF A SET PROGRAM

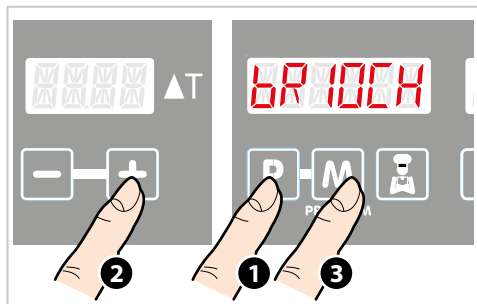

- ❶ Press the **P** button.
- ❷ Use the **-** **+** buttons to call to screen the program to modify.
- ❸ Reconfigure the program parameters as fully explained in the chapter "Manual Operation".
- ❹ Hold the **M** button until hearing the long "beep" sound. Now the modified parameters have been saved.

PURE (WATER FILTERING SYSTEM SETTINGS)



The PURE function accesses a hidden menu from which can be set the water softener filtering system (Reverse osmosis kit with "UNOX.Pure-RO" pump or "UNOX.Pure") filters.

Press the  button.

Press the **-** **+** buttons until "PURE" appears on screen "8".

Press the  button to access the menu.

By using the **-** **+** buttons it is possible to scroll through the three parameters END, PIN and HRD.

Pressing  when the screen displays a parameter (END, PIN or HDR) allows you to set it. After accessing a parameter, press  or wait 5 seconds to return to the previous screen.

HRD (hardness)

Allows to set the water hardness in French degrees, which is measured with the kit supplied

END

The residual litres are displayed before requiring filter replacement. The number of litres are only displayed and cannot be adjusted.

When the number of remaining litres is zero, the screen displays the warning message "WPURE".

When this warning is displayed:

- A) the filter is replaced and the new PIN on the package is entered to activate litre count;
- B) an incorrect PIN is entered: this deactivates litre countdown.

PIN

Use the **-** **+** buttons to write the PIN code of the filter (shown on its package) to activate the litre count. Hold down the **M** button to save the code. Entering an incorrect PIN calls up the "ERROR" message and the litre count is deactivated.



Oven-user communication (only mod. XL1005 - XEBPC-16EU-D - XEBPL-16EU-D *Dynamic*)

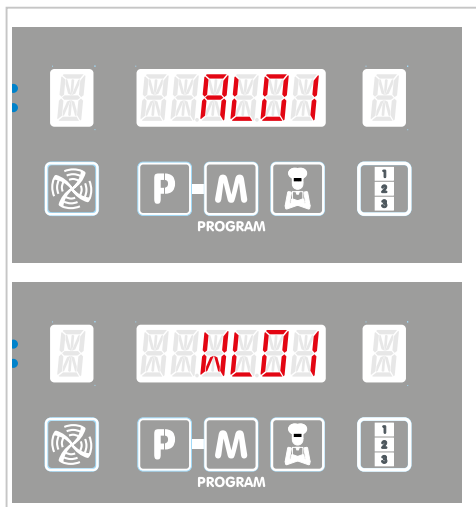

Any alarm/warning messages regarding the XL415 provers are shown on the display of the oven to which they are connected.

- The warning messages (**WARNING**) signal malfunctions that nevertheless allow the appliance to operate, though with a restricted set of functions.

Pressing the **P** button on the oven control panel deletes the Warning alarm list FROM THE DISPLAY.

- The alarm messages (**ALARM**) identify situations that do not allow any appliance operation whatsoever, and therefore must be put into STOP mode.

When there are several ALARM/WARNING MESSAGES, the user can scroll through these by repeatedly pressing START/STOP.

| Display | Description | Effect | Troubleshooting |
|--------------------------|---|---|---|
| AL - PROVER ALARM | | | |
| AL01 | Cavity probe alarm | The prover stops any operating cycle and stops any successive display screen settings | Contact the Customer Assistance Service |
| AL02 | Communications failure alarm | The prover stops any operating cycle and stops any successive display screen settings | |
| AL03 | No 230 V power supply to the prover board | The prover stops any operating cycle and stops any successive display screen settings | Check the prover power cable |

| Display | Description | Effect | Troubleshooting |
|----------------------------|-------------------------------------|---|---|
| WL - PROVER WARNING | | | |
| WL01 | Error humidity probe | The prover continues to run but the automatic humidity regulation feature cannot be engaged | Contact the Customer Assistance Service |
| WL02 | Error of temperature board | The prover continues to run | |
| WL03 | Error of resistor compartment probe | | |

Routine maintenance



Any routine maintenance procedure must be performed:

- after disconnecting the appliance from the power and water supplies;
- after having put on the proper personal protection equipment (i.e. gloves, etc...).

Clean the appliances on a daily basis in order to maintain a good level of hygiene and to avoid corrosion or deterioration of the stainless steel.



Do NOT clean using:

- abrasive or powder detergents;
- aggressive or corrosive detergents (i.e. hydrochloric/muriatic or sulphuric acid).
- abrasive or sharp tools (i.e. abrasive sponges, scrapers, steel bristled brushes, etc...);
- water sprays.

External steel structures, prover cavity seal

Wait for the surfaces to cool off.

Use only a soft cleaning cloth dampened with a little soap and water. Rinse and dry completely. In alternative, only use detergents recommended by UNOX; other products may cause damage thereby invalidating the guarantee. Read the instructions provided by the detergent producer for their use.

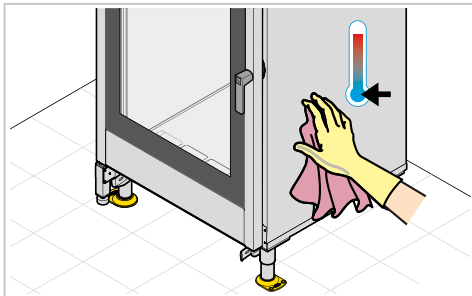

Internal door window

Wait for the windows to cool off.

Use only a soft cleaning cloth dampened with a little soap and water or specific glass cleaners. Rinse and dry completely.

Plastic surfaces and control panel

Use only a very soft cleaning cloth and a small amount of detergent for cleaning delicate surfaces.



Prover cavity

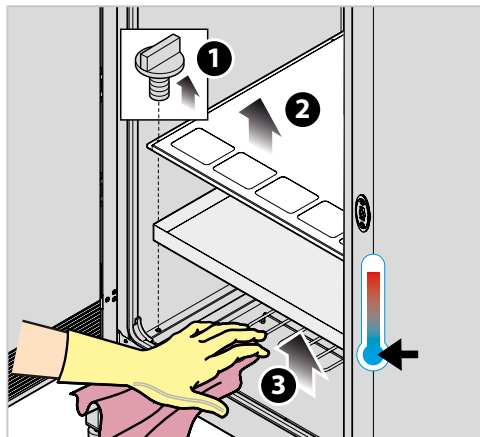

Follow the procedure below to clean the prover cavity:

- switch on the prover and set the temperature to 40°C; if using the XL1005 model also set the steam level (**STEAM.Maxi™**) at 100%;
- run the prover for 10 minutes;
- wait for the surfaces to cool off and clean with a soft cleaning cloth and non-aggressive cleaner;
- rinse completely to remove all residues.

To facilitate the cleaning of the chamber, remove the pan with lid as shown in figure **after having checked that the resistance is cold.**

Clean it with soapy water or specific cleaners; **do not clean using the dishwasher.**

Inside and outside oven door window glass

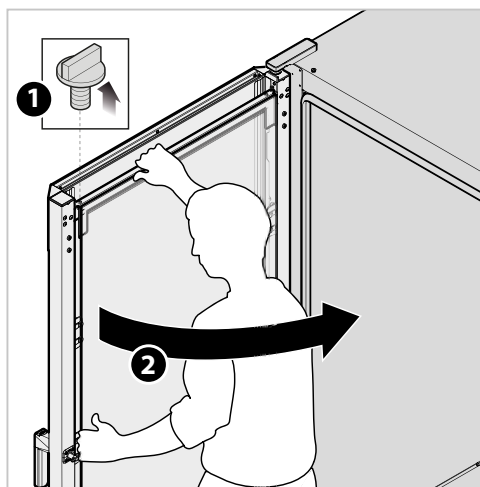

Use only a soft cleaning cloth dampened with a little soap and water or specific glass cleaners.

Rinse and dry completely.

If more thorough cleaning is necessary, the inside window can be opened by following the indications shown in the figure.

Cleaning the spray nozzle (only models XL1005 - XEBPC-16EU-D - XEBPL-16EU-D *Dynamic*)

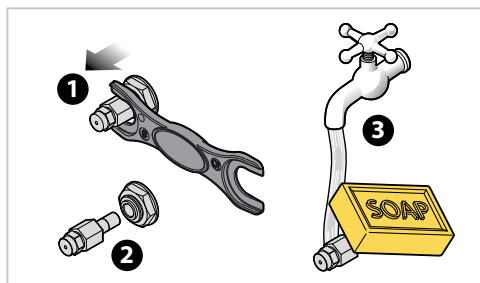

When needed, extract the sprayer and clean it with soapy water, finishing with a rinse.

If it needs to be descaled, immerse it for a few hours in warm vinegar: at the end rinse it and put it back in place.

When cleaning do not use aggressive cleaning agents, acids or chemical scale removers!

Inactivity

Follow the precautions below during inactivity:

- disconnect the appliance from the power and water supplies;
- it is preferable to rub a soft cloth lightly doused with mineral oil on all stainless steel surfaces;

At first reuse:

- clean the appliance and its accessories thoroughly (see chapter "**Routine maintenance**" on page 35);
- connect the appliance to its power and water supplies;
- inspect the appliance before using it;



It is best to have an authorized customer assistance service perform maintenance and inspection on the appliance at least once a year to ensure top working and safety conditions.

Disposal at end of life

According to Art. 3 of the Decreto Legislativo n.49 of the Italian Legislation of the 2014 "Implementation of the WEEE Directive on Waste Electrical and Electronic Equipment 2012/19/EU".



The WEEE symbol of a crossed out wheeled bin with a black line under it specifies that the product has been placed on the market after the 13th August 2005 and that at the end of its life it must not be disposed of together with other refuse but must be disposed of separately.

■ All the equipment has been made with recyclable metal materials (stainless steel, iron, aluminium, zinc plate, copper, etc.) that as a percentage make up more than 90% of the weight.

The equipment must be made ready for disposal by removing the power cable and closing the door or any cavities (where present).

Attention must be paid to the management of this product at the end of its life, reducing any negative impact on the environment and improving the efficiency of resources, applying the principles of "who pollutes pays", prevention, preparation for re-use, recycling and recovery. An illegal or non-correct disposal of the product will lead to sanctions being applied as per current legislation.

Information on disposal in Italy

In Italy all WEEE equipment must be delivered:

- to Collection Centres (also named "eco-islands" or "eco-platforms")
- to the dealers from which new equipment has been purchased, who is bound to collect the old equipment free-of-charge ("one in one out" collection);

Information on disposal in European Union countries

The EU Directives on WEEE equipment has been implemented in different ways by different countries, therefore in order to dispose of this equipment correctly we suggest that you contact your local authority or your dealer in order to ask the correct method of disposal.



After-sales assistance

In case of any malfunctions, disconnect the appliance from its power and water supply. Consult the solutions proposed in the “**Table C**”.



If the solution is not listed in the table, contact a UNOX authorized technical customer service. Provide the following information:

- the date of purchase;
- the appliance data on the serial plate;
- (only mod. XL1005 - XEBPC-16EU-D - XEBPL-16EU-D) any alarm messages that are shown on the display of the oven connected to the prover (see chapter “**Oven-user communication (only mod. XL1005 - XEBPC-16EU-D - XEBPL-16EU-D Dynamic)**” on page 34).

Manufacturer's information:

UNOX S.p.A.
Via Majorana, 22
35010 Cadoneghe (PD) Italy
Tel +39 049 86.57.511 - Fax +39 049 86.57.555
info@unox.com www.unox.com

Table C

| Malfunction | Possible cause | Possible solution | |
|--|--|---|---|
| The prover fails to heat when a leavening cycle is activated. | The prover is not connected to the power supply. | Connect to the power supply. | |
| | The P.C.B. is damaged. | Contact the Customer Assistance Service | |
| | The prover resistor is damaged. | | |
| | The prover temperature sensor is damaged. | | |
| (only mod. XL1005) No humidity is generated when a leavening cycle is started | only models XL1005 XEBPC-16EU - XEBPL-16EU-D | The prover was not connected to the oven vis RJ45 cable during installation. | Contact the Customer Assistance Service |
| | | The RJ45 cable that connects the oven to the prover is disconnected or damaged. | |
| | | The prover is not connected to the water supply. | Connect the prover to the water supply. |
| | | The water intake solenoid is damaged. | Contact the Customer Assistance Service |
| | | The P.C.B. is damaged. | |
| | The prover humidity probe is damaged. | | |

Certification

EU declaration of conformity for electrical appliances

Manufacturer: UNOX S.p.A.

Address: Via Majorana, 22 - 35010 Cadoneghe, Padua, Italy

Declares, under its own responsibility, that the products:

XL1003 - XL1005 - XEBPC-16EU-M - XEBPC-16EU-D - XEBPL-16EU-M - XEBPL-16EU-D

comply with EM Compatibility Directive 2014/35/EC through the following standards:

EN 60335-1: 2014 + A11:2014

EN 60335-2-49: 2003 + A1: 2008 + A11:2012

EN62233: 2008

comply with EM Compatibility Directive 2014/30/EC through the following standards:

EN 55014-1: 2006 + A1: 2009 + A2: 2011

EN 55014-2: 1997 + A1: 2001 + A2: 2008

EN 61000-3-2: 2006 + A1: 2009 + A2: 2009

EN 61000-3-3: 2008

EN 61000-3-11: 2000

EN 61000-3-12: 2011

EN 61000-6-2: 2005

EN 61000-6-3: 2007

Guarantee

Installation of the UNOX product must be performed by an Authorized UNOX Assistance Service. The installation date and appliance model must be documented by the end purchaser, by means of written confirmation or an installation invoice issued by the dealer or the Authorised UNOX Customer Assistance Service, otherwise this guarantee will not be valid;

The UNOX guarantee covers all malfunctions objectively linked to production defects. The guarantee excludes damage due to transport, poor product storage or maintenance or incorrect product use. Also excluded is damage due to installation not conforming to the technical specifications provided by Unox and linked to the environment



INTERNATIONAL

UNOX S.p.A.

Via Majorana 22 / 35010 Cadoneghe (PD) Italy
Tel +39 049 8657511 / Fax +39 049 8657555

info@unox.com



INVENTIVE SIMPLIFICATION

EUROPE

ITALIA

UNOX S.p.A.
E-mail: info@unox.it
Tel.: +39 049 86 57 511

ČESKÁ REPUBLIKA

UNOX DISTRIBUTION s.r.o.
E-mail: info.cz@unox.com
Tel.: +420 241 940 000

РОССИЯ, ПРИБАЛТИКА И СТРАНЫ СНГ

UNOX ROSSIA
E-mail: info.ru@unox.com
Tel.: +7 (499) 702-00-14

ESPAÑA

UNOX PROFESIONAL ESPAÑA S.L.
E-mail: info.es@unox.com
Tel.: +34 900 82 89 43

SCANDINAVIAN COUNTRIES

UNOX SCANDINAVIA AB
E-mail: info.se@unox.com
Tel.: +46 (0)768 716 422

UNITED KINGDOM

UNOX UK Ltd.
E-mail: info@unoxuk.com
Tel.: +44 1252 851 522

PORTUGAL

UNOX PORTUGAL
E-mail: info.pt@unox.com
Tel.: +351 918 228 787

DEUTSCHLAND

UNOX DEUTSCHLAND GmbH
E-mail: info.de@unox.com
Tel.: +49 2951 98760

FRANCE, BELGIUM & LUXEMBOURG

UNOX FRANCE s.a.s.
E-mail: info@unox.fr
Tel.: +33 4 78 17 35 39

ÖSTERREICH

UNOX ÖSTERREICH GmbH
E-mail: bestellung@unox.com
Tel.: +43 800 880 963

HRVATSKA

UNOX CROATIA
E-mail: narudzbe@unox.com
Tel.: +39 049 86 57 538

TÜRKİYE

UNOX TURKEY Profesyonel Mutfak
Ekipmanları Endüstri ve Ticaret Limited Şirketi
E-mail: info.tr@unox.com
Tel.: +90 530 176 62 03

IRELAND

UNOX IRELAND
E-mail: info.ie@unox.com
Tel.: +353 (0) 87 32 23 218

БЪЛГАРИЯ

UNOX BULGARIA
E-mail: info.bg@unox.com
Tel.: +359 88 213 378

ASIA & AFRICA

MALAYSIA & SINGAPORE

UNOX (ASIA) SDN. BHD
E-mail: info.asia@unox.com
Tel.: +603-58797700

OTHER ASIAN COUNTRIES

UNOX (ASIA) SDN. BHD
E-mail: info.asia@unox.com
Tel.: +603-58797700

PHILIPPINES

UNOX PHILIPPINES
E-mail: info.asia@unox.com
Tel.: +63 9173108084

대한민국

UNOX KOREA CO. Ltd.
이메일: info.asia@unox.com
전화: +82 2 69410351

AMERICA & OCEANIA

U.S.A. & CANADA

UNOX Inc.
E-mail: info.usa@unox.com
Tel.: +1 800 489 8669

MEXICO

UNOX MEXICO, S. DE R.L. DE C.V.
E-mail: info.mx@unox.com
Tel.: +52 1555 4314 180

BRAZIL

UNOX BRAZIL
E-mail: info.br@unox.com
Tel.: +55 11 98717-8201

U.A.E.

UNOX MIDDLE EAST DMCC
E-mail: info.uae@unox.com
Tel.: +971 55 426 3167

SOUTH AFRICA

UNOX SOUTH AFRICA
E-mail: info.sa@unox.com
Tel.: +27 845 05 52 35

INDONESIA

UNOX INDONESIA
E-mail: info.asia@unox.com
Tel.: +62 81908852999

中华人民共和国

UNOX TRADING (SHANGHAI) CO. Ltd.
电子邮件: info.china@unox.com
电话: +86 21 56907696

COLOMBIA

UNOX COLOMBIA
E-mail: info.co@unox.com
Tel.: +57 350 65 88 204

AUSTRALIA

UNOX AUSTRALIA PTY Ltd.
E-mail: info@unoxaustralia.com.au
Tel.: +61 3 9876 0803

NEW ZEALAND

UNOX NEW ZEALAND Ltd.
E-mail: info@unox.co.nz
Tel.: +64 (0) 800 76 0803

UNOX.COM | FOLLOW US ON



LI2377BI,DOO-L,DI-01 - Printed: 01-2019

All images used are for illustrative purposes only.

All features indicated in this catalogue may be subject to change and could be updated without notice.