

07/2019

EN

Dishwasher technical manual

ADVANCE (DGT)

CONTENTS

CONTENTS.....	2
MEANING OF THE ICONS	3
USER INTERFACE.....	4
WASH PROGRAMS	6
DETERGENT ADJUSTMENT.....	8
Detergent dispenser adjustment.....	8
Rinse aid dispenser adjustment.....	9
Tank and boiler capacity table.....	10
DIP-SWITCH ADJUSTMENT	11
Blue dip-switch block adjustments.....	11
Red dip-switch block adjustments.....	13
BOARD SETTINGS.....	16
TERMO-STOP	17
Tank thermo-stop adjustment.....	17
Boiler thermo-stop adjustment.....	18
RINSE TIME	19
Pressure control system 103367	20
DRAIN PUMP SETTING	22
Draining the dishwasher	23
MENU.....	24
Accessing the menu.....	24
PROGRAMMED MAINTENANCE	25
Maintenance program.....	26
Basic periodic/annual maintenance kit	27
DEFINED ALARMS	28

MEANING OF THE ICONS



ON/OFF: backlit button to switch dishwasher on/off



SELECTION: backlit button to select program



START CYCLE / START: backlit button



HEATING: with the light on, it indicates that the tank or boiler heating element is on



ALARM: with the light on, it indicates the presence of an alarm



MAINTENANCE: with the light on, it indicates scheduled maintenance is required



PROGRAMS: 4 wash programs



DRAIN: drain program

USER INTERFACE

The image shows the dishwasher control panel and the control references.

CONTROLS	REF.
ON/OFF BUTTON	1
LEFT DIGIT LED	2
TANK TEMPERATURE LIGHT	3
RIGHT DIGIT LED	4
BOILER TEMPERATURE LIGHT	5
PROGRAM SELECTION BUTTON	6
CYCLE START / START BUTTON	7
ALARM LIGHT	8
MAINTENANCE REQUIRED LIGHT	9

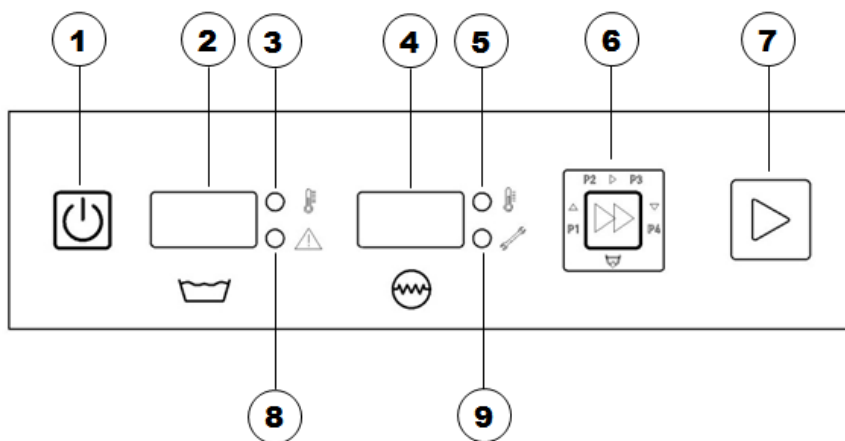

1- ON/OFF BUTTON. When the dishwasher is powered electrically, the backlit ON/OFF button is always on

2- LEFT DIGIT LED

4- RIGHT DIGIT LED

show:

- the tank and boiler temperatures

- some useful messages to understand the dishwasher status:

OFF: dishwasher off. The message appears when the dishwasher is switched off but disappears after 2 seconds.

Fill: appears while the tank is filling up

P1 – P2 – P3 – P4: show the reference program on the display

dr: abbreviation of “drain”; indicates the drain program (only present on dishwashers with a drain pump installed and enabled)

End: appears at the end of the wash cycle

Hi: high temperature. It appears on the display when the boiler or tank temperature reaches 100°C. This wording automatically disappears when the temperature drops below 100°C

AL: alarm. This message is always accompanied by an alarm code that indicates the type of alarm triggered.

tSb: boiler thermo-stop. It appears during the wash cycle during the thermo-stop stage (see paragraph relating to the thermo-stop)

3- TANK TEMPERATURE LIGHT. If the light is on, the tank resistance is active

5- BOILER TEMPERATURE LIGHT. If the light is on, the boiler resistance is active

6- PROGRAM SELECTION BUTTON. With the dishwasher ready to be used, pressing the program selection button several times scrolls through the 4 saved programs. When scrolling through the programs, the program code will appear on the LEFT DIGIT LEDs (2), whereas the duration of the program (in seconds) will appear on the RIGHT DIGIT LEDs (4).

P1 (program 1)

P2 (program 2)

P3 (program 3)

P4 (program 4)

dr (drain program that is only present if the drain pump is installed; the duration is not indicated for this program)

7- CYCLE START BUTTON. This button can change colour depending on the status of the dishwasher:

FILLING: red



HEATING: yellow



READY: green



CURRENT CYCLE: flashing blue

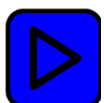

ALARM: red



WASH PROGRAMS

There are 4 wash programs (P1, P2, P3, P4)

The wash time cannot be changed however the rinse time can. The set rinse time is shared between all 4 programs.

The total wash time changes according to the:

- Type of dishwasher: undercounter or hood type dishwasher
- Set rinse time*: 10", 12", 15"(default value), 20"
- Activated/deactivated drain pump. If the drain pump is activated, the total cycle time varies according to the set drain time* (10", 20" 35")

*For the rinse and drain times to be changed, refer to the "Dip-switch adjustment" chapter

UNDERCOUNTER DISHWASHER			
<i>the total cycle varies according to the set rinse time</i>			
10"	12"	15" (default)	20"

	Drain pump	Wash	Pause	Total cycle	Total cycle	Total cycle	Total cycle
Without drain pump	OFF	70	5	85	87	90	95
		100	5	115	117	120	125
		130	5	145	147	150	155
		160	5	175	177	180	185
Drain pump installed	10"	70	10	90	92	95	100
		100	10	120	122	125	130
		130	10	150	152	155	160
		160	10	180	182	185	190
	20"	70	20	100	102	105	110
		100	20	130	132	135	140
		130	20	160	162	165	170
		160	20	190	192	195	200
	35"	70	35	115	117	120	125
		100	35	145	147	150	155
		130	35	175	177	180	185
		160	35	205	207	210	215

HOOD TYPE DISHWASHER

the total cycle varies according to the set rinse time

10"	12"	15" (default)	20"
-----	-----	---------------	-----

	Drain pump	Wash	Drain Pause	Total cycle	Total cycle	Total cycle	Total cycle
Without drain pump	OFF	40	5	55	57	60	65
		70	5	85	87	90	95
		100	5	115	117	120	125
		220	5	235	237	240	245
Drain pump installed	10"	40	10	60	62	65	70
		70	10	90	92	95	100
		100	10	120	122	125	130
		220	10	240	242	245	250
	20"	40	20	70	72	75	80
		70	20	100	102	105	110
		100	20	130	132	135	140
		220	20	250	252	255	260
	35"	40	35	85	87	90	95
		70	35	115	117	120	125
		100	35	145	147	150	155
		220	35	265	267	270	275

DETERGENT ADJUSTMENT

The detergents are adjusted by directly turning the specific adjustment screw, found on the detergent and rinse aid dispensers fitted on the machine.

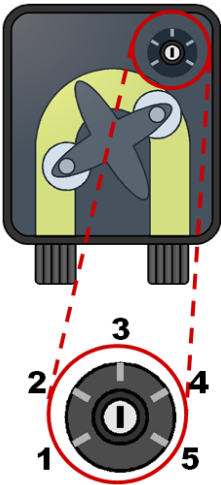

The detergent dispenser and the rinse aid dispenser have different functions and therefore, the calculation is made differently:

Detergent dispenser adjustment

Refer to the following table for the adjustment calculation:

	Dosage gr/sec				
	1	2	3	4	5
DETERGENT	Off	0.24	0.48	0.73	0.97

The following must be known in order to understand on which position to adjust the dispenser:

- water consumption per cycle (CA)
- recommended dosage by the detergent manufacturer in grams per litre (DD)
- rinse time adjustment (TR)

the calculation formula is:

$$CA \cdot DD / TR$$

Example

- water consumption per cycle (CA): 2 litres
- recommended dosage by the detergent manufacturer (DD): 3 gr/litre
- rinse time adjustment (TR): 15 seconds

$CA \cdot DD / TR \rightarrow 2 \cdot 3 / 15 = 0.4$ therefore, the dispenser must be set to position 3

Rinse aid dispenser adjustment

Refer to the following table for the adjustment calculation:

	<i>Dosage gr</i>				
	1	2	3	4	5
RINSE AID	Off	0.6	1.2	1.8	2.4

The rinse aid dispenser has fixed dosages for each adjustment position, therefore, you must know the following to set the correct dosage:

- water consumption per cycle (CA)
- recommended dosage by the rinse aid manufacturer in grams/litre (DB)

the calculation formula is:

CA*DB

Example

- water consumption per cycle (CA): 2 litres
- recommended dosage by the rinse aid manufacturer (DB): 0.8 gr/litre

CA*DB → 2*0.8=1.6 therefore, the dispenser must be set between position 3 and position 4

Tank and boiler capacity table

GLASSWASHER			
Basket Size (mm)	Tank Capacity (l)	Boiler Capacity (l)	Water consumption per cycle (l) at 2 BAR
350x350	13	3.2	2
400x400	17	3.2	2
400x400 water refill	5	6.1	2
UNDERCOUNTER DISHWASHER			
Basket Size (mm)	Tank Capacity (l)	Boiler Capacity (l)	Water consumption per cycle (l) at 2 BAR
450x450	20	7.3	2
500x500	26	7.3	2
500x500 water refill	13	7.3	2
500x600	30	7.3	2
HOOD TYPE DISHWASHER			
Basket Size (mm)	Tank Capacity (l)	Boiler Capacity (l)	Water consumption per cycle (l) at 2 BAR
500x500	37	7.3	2
500x600	37	7.3	2
600x670	37	7.3	2
WAREWASHER			
Basket Size (mm)	Tank Capacity (l)	Boiler Capacity (l)	Water consumption per cycle (l) at 2 BAR
600x670	37	13.6	2
725x850	100	13	3
no.2 600x670	100	21	4

DIP-SWITCH ADJUSTMENT

The power board is fitted with 2 blocks with 8 dip-switches for each block.

The blue block enables certain settings to be changed, whereas the red block allows the temperatures and thermo-stop of both the tank and the boiler to be changed.

The various adjustments are provided below:

Blue dip-switch block adjustments

- Testing
- Type of check (digital/electromechanical).
- Tank thermo-stop (active/deactive). **Active** by default
- Boiler thermo-stop (active/deactive). **Active** by default
- Rinse time adjustment: Default **15sec**
- Drain time adjustment

Testing	Digital check	Tank Thermo-Stop ON	Boiler Thermo-Stop ON	Rinse time	Rinse time	Drain time	Drain time
	■	■	■	■			
■					■	■	■
1	2	3	4	5	6	7	8
Normal operation	Electromechanical control	Tank Thermo-Stop OFF	Boiler Thermo-Stop OFF	Rinse time	Rinse time	Drain time	Drain time

10" rinse time adjustment

	■			■	■		
■							
1	2	3	4	5	6	7	8

12" rinse time adjustment

	■				■		
■				■			
1	2	3	4	5	6	7	8

15" rinse time adjustment

	■			■			
■					■		
1	2	3	4	5	6	7	8

20" rinse time adjustment

	■						
■				■	■		
1	2	3	4	5	6	7	8

Drain pump OFF

	■						
■						■	■
1	2	3	4	5	6	7	8

10" drain time adjustment

	■					■	■
■							
1	2	3	4	5	6	7	8

20" drain time adjustment

	■						■
■						■	
1	2	3	4	5	6	7	8

35" drain time adjustment

	■					■	
■							■
1	2	3	4	5	6	7	8

Red dip-switch block adjustments

- Tank thermo-stop adjustment. **15°C** by default
- Boiler thermo-stop adjustment. **15°C** by default
- Tank temperature. Default **55°C**
- Boiler temperature. Default **75°C**

Tank thermo-stop setting	Tank thermo-stop setting	Boiler thermo-stop setting	Boiler thermo-stop setting	Tank temperature	Tank temperature	Boiler temperature	Boiler temperature
■		■			■	■	■
	■		■	■			
1	2	3	4	5	6	7	8
Tank thermo-stop setting	Tank thermo-stop setting	Boiler thermo-stop setting	Boiler thermo-stop setting	Tank temperature	Tank temperature	Boiler temperature	Boiler temperature

5°C tank thermo-stop adjustment

■	■						
1	2	3	4	5	6	7	8

10°C tank thermo-stop adjustment

	■						
■							
1	2	3	4	5	6	7	8

15°C tank thermo-stop adjustment

■							
	■						
1	2	3	4	5	6	7	8

20°C tank thermo-stop adjustment

■	■						
1	2	3	4	5	6	7	8

5°C boiler thermo-stop adjustment

		■	■				
1	2	3	4	5	6	7	8

10°C boiler thermo-stop adjustment

			■				
		■					
1	2	3	4	5	6	7	8

15°C boiler thermo-stop adjustment

		■					
			■				
1	2	3	4	5	6	7	8

20°C boiler thermo-stop adjustment

		■	■				
1	2	3	4	5	6	7	8

50°C tank temperature adjustment

				■	■		
1	2	3	4	5	6	7	8

55°C tank temperature adjustment

					■		
				■			
1	2	3	4	5	6	7	8

60°C tank temperature adjustment

				■			
					■		
1	2	3	4	5	6	7	8

65°C tank temperature adjustment

				■	■		
1	2	3	4	5	6	7	8

75°C boiler temperature adjustment

						■	■
1	2	3	4	5	6	7	8

80°C boiler temperature adjustment

							■
						■	
1	2	3	4	5	6	7	8

85°C boiler temperature adjustment

						■	
							■
1	2	3	4	5	6	7	8

88°C boiler temperature adjustment

						■	■
1	2	3	4	5	6	7	8

BOARD SETTINGS

Dip-switch 1 is used internally to program and test the board, therefore, it must always be set to OFF.

If, by mistake, dip-switch 1 is set to ON and then to OFF, disconnect and reconnect power to the dishwasher in order to reset the test setting.

Dip-switch 2 is used to select the type of interface connected to the electronic board:

- ON for digital control as shown in the image below

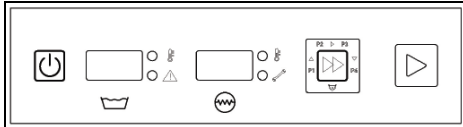

- OFF electromechanical control with buttons as shown in the image below:

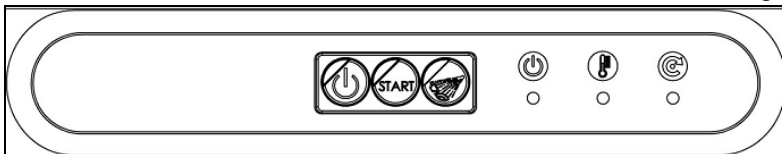

	Testing	Digital check						
		■						
	■							
	1	2	3	4	5	6	7	8
Normal operation		Electromechanical control						

TERMO-STOP

The dishwasher is fitted with the standard thermo-stop function that guarantees the start of the wash cycle only if the tank water temperature has reached the minimum value set (Tank Thermo-stop) and enables the rinse only if the boiler has reached the minimum temperature set (Boiler Thermo-stop).

The boiler temperature is verified at the end of the wash cycle, before starting the rinse:

- If the temperature is above the minimum value, the cycle proceeds correctly with the rinse.
- If the temperature is below the minimum value, the wash cycle is extended until the minimum temperature is reached.

It is possible to activate/deactivate the tank thermo-stop from dip-switch 3 of the blue block

		ON						
		OFF						
1	2	3	4	5	6	7	8	

CAUTION: by deactivating the tank thermo-stop, the wash cycle can also be started with cold water, with the risk of foam being produced. Therefore, it cannot be guaranteed that the dishwasher will function properly or that the dishes will be washed and sanitised correctly.

It is possible to activate/deactivate the boiler thermo-stop from dip-switch 4 of the blue block

			ON					
			OFF					
1	2	3	4	5	6	7	8	

CAUTION: by deactivating the boiler thermo-stop, rinsing will also be performed with the boiler cold, with the risk of cooling the wash water. Therefore, no guarantee can be given that the dishwasher will function properly or that the dishes will be rinsed and sanitised correctly.

Tank thermo-stop adjustment

Actuating dip-switches 1 and 2 of the red block, adjusts the tank thermo-stop. The set value will be common to the 4 cycles. This value coincides with the dishwasher operating window and enables to calculate the minimum temperature.

For example, by setting a tank temperature of 55°C and a thermo-stop of 5°C, the wash cycle will only start if the tank temperature is higher than 50°C (value based on the difference 55 - 5). Otherwise, the START CYCLE button will be red and it will not be possible to start the wash cycle.

5°C tank thermo-stop adjustment

■	■							
1	2	3	4	5	6	7	8	

10°C tank thermo-stop adjustment

	■							
■								
1	2	3	4	5	6	7	8	

15°C tank thermo-stop adjustment

<input checked="" type="checkbox"/>	<input type="checkbox"/>	<input type="checkbox"/>	<input type="checkbox"/>	<input type="checkbox"/>	<input type="checkbox"/>	<input type="checkbox"/>	<input type="checkbox"/>
<input type="checkbox"/>	<input checked="" type="checkbox"/>	<input type="checkbox"/>	<input type="checkbox"/>	<input type="checkbox"/>	<input type="checkbox"/>	<input type="checkbox"/>	<input type="checkbox"/>
1	2	3	4	5	6	7	8

20°C tank thermo-stop adjustment

<input type="checkbox"/>	<input type="checkbox"/>	<input type="checkbox"/>	<input type="checkbox"/>	<input type="checkbox"/>	<input type="checkbox"/>	<input type="checkbox"/>	<input type="checkbox"/>
<input checked="" type="checkbox"/>	<input checked="" type="checkbox"/>	<input type="checkbox"/>	<input type="checkbox"/>	<input type="checkbox"/>	<input type="checkbox"/>	<input type="checkbox"/>	<input type="checkbox"/>
1	2	3	4	5	6	7	8

Boiler thermo-stop adjustment

Operating dip-switches 3 and 4 of the red block adjusts the boiler thermo-stop. The set value will be common to the 4 cycles. This value coincides with the dishwasher rinse window and enables to calculate the minimum temperature. For example, by setting a boiler temperature of 75°C and a thermo-stop of 5°C, the rinse cycle will only start if the boiler temperature is higher than 70°C (value based on the difference 75 - 5). Otherwise the wash cycle is extended until the minimum temperature is reached.

5°C boiler thermo-stop adjustment

<input type="checkbox"/>	<input type="checkbox"/>	<input checked="" type="checkbox"/>	<input checked="" type="checkbox"/>	<input type="checkbox"/>	<input type="checkbox"/>	<input type="checkbox"/>	<input type="checkbox"/>
<input type="checkbox"/>	<input type="checkbox"/>	<input type="checkbox"/>	<input type="checkbox"/>	<input type="checkbox"/>	<input type="checkbox"/>	<input type="checkbox"/>	<input type="checkbox"/>
1	2	3	4	5	6	7	8

10°C boiler thermo-stop adjustment

<input type="checkbox"/>	<input type="checkbox"/>	<input type="checkbox"/>	<input checked="" type="checkbox"/>	<input type="checkbox"/>	<input type="checkbox"/>	<input type="checkbox"/>	<input type="checkbox"/>
<input type="checkbox"/>	<input type="checkbox"/>	<input checked="" type="checkbox"/>	<input type="checkbox"/>	<input type="checkbox"/>	<input type="checkbox"/>	<input type="checkbox"/>	<input type="checkbox"/>
1	2	3	4	5	6	7	8

15°C boiler thermo-stop adjustment

<input type="checkbox"/>	<input type="checkbox"/>	<input checked="" type="checkbox"/>	<input type="checkbox"/>	<input type="checkbox"/>	<input type="checkbox"/>	<input type="checkbox"/>	<input type="checkbox"/>
<input type="checkbox"/>	<input type="checkbox"/>	<input type="checkbox"/>	<input checked="" type="checkbox"/>	<input type="checkbox"/>	<input type="checkbox"/>	<input type="checkbox"/>	<input type="checkbox"/>
1	2	3	4	5	6	7	8

20°C boiler thermo-stop adjustment

<input type="checkbox"/>	<input type="checkbox"/>	<input type="checkbox"/>	<input type="checkbox"/>	<input type="checkbox"/>	<input type="checkbox"/>	<input type="checkbox"/>	<input type="checkbox"/>
<input type="checkbox"/>	<input type="checkbox"/>	<input checked="" type="checkbox"/>	<input checked="" type="checkbox"/>	<input type="checkbox"/>	<input type="checkbox"/>	<input type="checkbox"/>	<input type="checkbox"/>
1	2	3	4	5	6	7	8

RINSE TIME

Actuating dip-switches 5 and 6 of the blue block, adjusts the rinse time.

The rinse time determines the water consumption of the dishwasher; therefore, consumption of approximately 2 litres of water/cycle is guaranteed by setting a value according to the dynamic pressure which the dishwasher is supplied with.

Dynamic pressure (bar)	Rinse time
1.5 – 1.9	20
2.0 – 2.4	15
2.5 – 2.9	12
3.0 – 3.5	10
>3.5	Use pressure reducer code 103367

10" rinse time adjustment

				■	■		
1	2	3	4	5	6	7	8

12" rinse time adjustment

					■		
				■			
1	2	3	4	5	6	7	8

15" rinse time adjustment

				■			
					■		
1	2	3	4	5	6	7	8

20" rinse time adjustment

				■	■		
1	2	3	4	5	6	7	8

NOTE: changing the rinse time also changes the total duration of the wash cycle.

Pressure control system 103367

With pressures above 3 BAR it is always advisable to install the control system code 103367

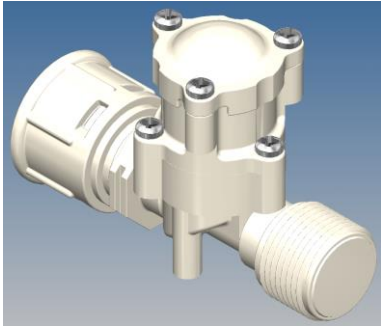

As can be seen from the graph, with inlet pressures greater than 2 BAR, the device maintains the outlet pressure fairly constant, always between 2 and 2.4 BAR.

Installation is very simple: it is sufficient to set it between the tap and the loading pipe of the dishwasher, taking care to respect the correct direction of the water flow indicated by the arrow:

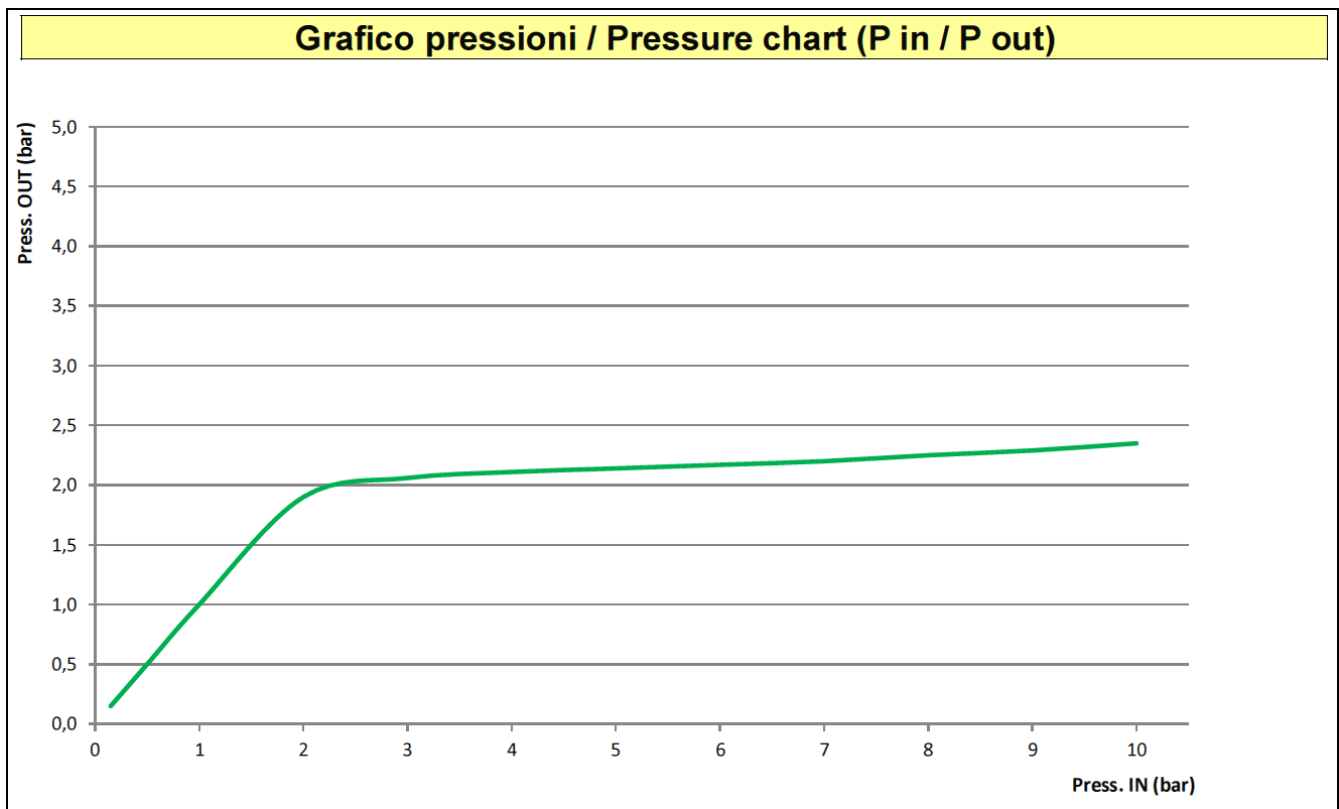
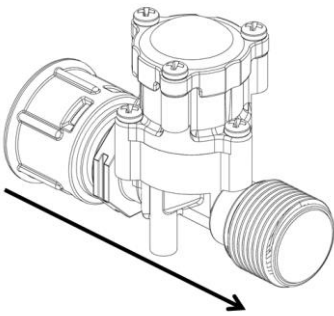

We recommend installing the mesh filter code 103366 upstream of the reducer itself, so as to preserve the pressure reducer.
Cleaning the filter is very simple as it is sufficient to unscrew the cap to extract the small mesh, even without disconnecting the water.

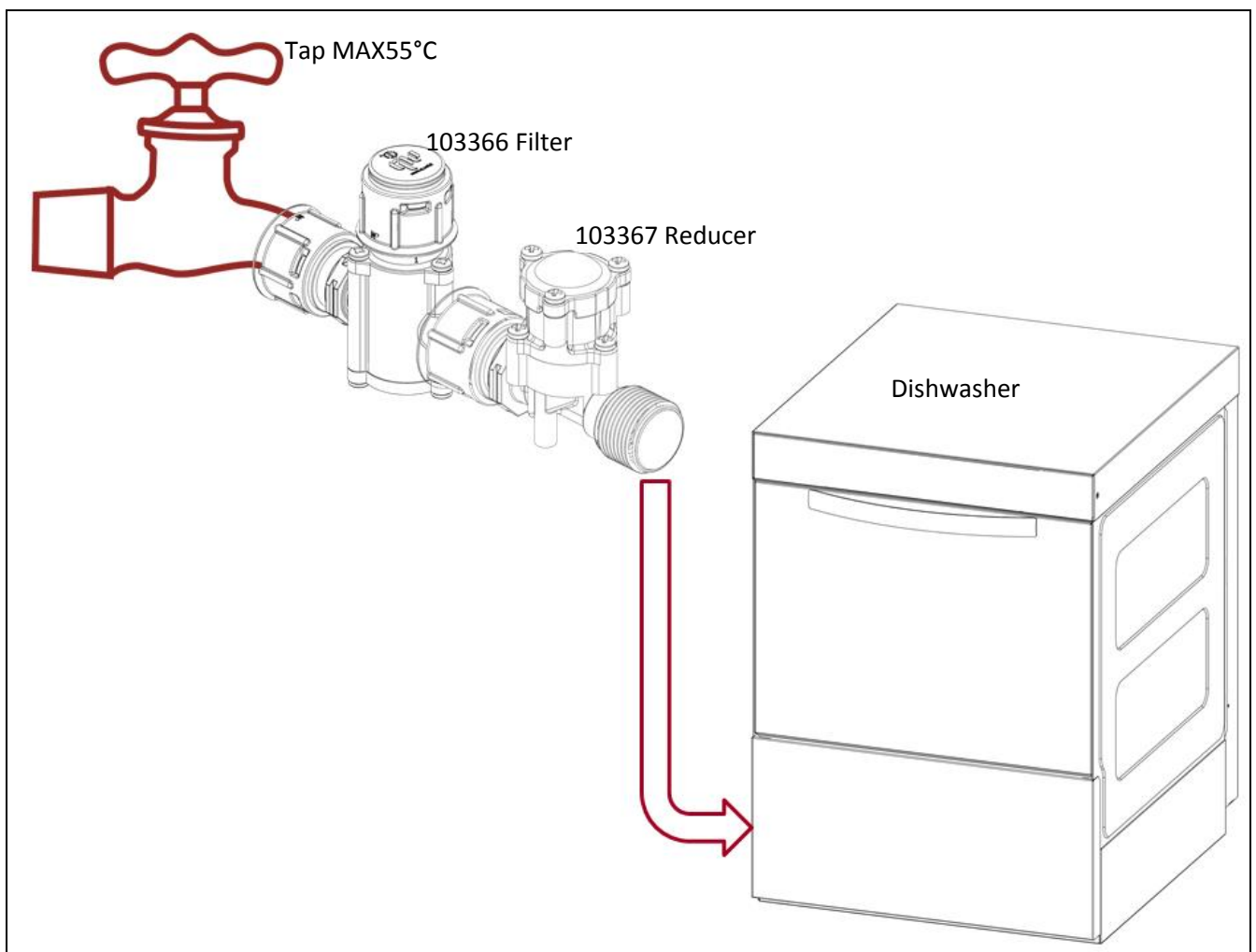
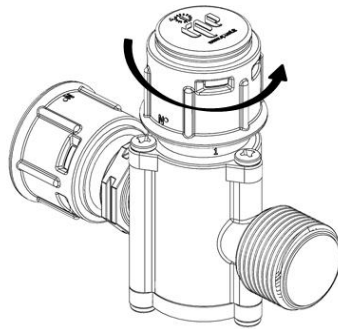

Installation diagram

DRAIN PUMP SETTING

Actuate dip-switches 7 and 8 to:

- Activate/deactivate the drain pump
- Change the drain times between cycles

By activating the drain pump, the total cycle changes duration. The pause (which in this case will coincide with the drain time) will become longer according to the drain time set on the dip-switches:

Drain pump OFF

						■	■
1	2	3	4	5	6	7	8

10" drain time adjustment

						■	■
1	2	3	4	5	6	7	8

20" drain time adjustment

							■
						■	
1	2	3	4	5	6	7	8

35" drain time adjustment

						■	
							■
1	2	3	4	5	6	7	8

WASH Set time	PAUSE/DRAIN Variable time on dip-switches 7-8	RINSE Variable time on dip-switches 5-6
------------------	-----------------------------------------------------	-----------------------------------------------

When installing the dishwasher, it is recommended to run a few wash cycles so as to make sure that the time set for draining is sufficient to eliminate about 3 litres of water which are then replenished with rinsing.

Decrease the drain time if the level in the tank decreases between cycles

Increase the drain time if the level in the tank increases between cycles

NOTE: with the drain pump installed, the water level in the tank may vary depending on the:

- **Set drain time**
- **Inlet water pressure** (the higher the inlet pressure, the more water will be introduced into the tank during the rinse. See the previous chapter for the correct calibration of the rinse time)
- **Drain pipe height** (it is advisable to use a maximum height of 45cm from the ground)
- **Drain pipe positioning** (too many bends prevent the pump from functioning correctly)
- **Cleaning the pump filter**

Make sure to always check all the variables described above to make sure the dishwasher functions properly.

Draining the dishwasher

The dishwasher must be drained once the work is completed:

- Remove the overflow element
- Close the door
- Repeatedly press the PROGRAM SELECTION BUTTON, until the “**dr**” program is reached (drain)
- Keep the CYCLE START BUTTON pressed to start the drain cycle

The drain cycle starts with the following times:

Undercounter dishwasher	5" ON	5" OFF	110" ON	5" OFF	5" ON	OFF
-------------------------	-------	--------	---------	--------	-------	-----

Dishwasher hood	5" ON	5" OFF	190" ON	5" OFF	5" ON	OFF
-----------------	-------	--------	---------	--------	-------	-----

Drain times for the tank to be emptied are fixed and cannot be changed.

MENU

You can access a menu from the display to:

- Verify the executed cycles
- Reset the maintenance required alarm
- Check the digit settings without opening the control panel
- Check the installed firmware version

Accessing the menu

- Turn the dishwasher off (OFF)
- Hold down the PROGRAM SELECTION and CYCLE START buttons simultaneously
- Scroll the items by pressing the PROGRAM SELECTION button repeatedly
- If you do not touch any button for 20", you will exit the menu
- Exit the menu by holding down the ON/OFF button

The following items will be displayed:

Code	Description	Actions
Par	Partial cycle counter	Displays the number of complete wash cycles executed since the counter was last reset
		Once the 80,000 cycles are completed, the maintenance warning will be displayed. Reset it by pressing and holding the CYCLE START BUTTON (see the next chapter)
tot	Total cycle counter	Displays the total number of complete wash cycles executed since the first use of the dishwasher
		Not resettable, read only
tU	Wash time	Indicates the wash time of the first cycle
		Read only
riS	Rinse time	Indicates the rinse time set on dip-switches 5 and 6 blue
		Read only
drA	Drain time	Indicates the rinse time set on dip-switches 7 and 8 blue
		Read only
tb	Boiler temperature	Indicates the boiler temperature set on dip-switches 7 and 8 red
		Read only
tSb	Boiler thermo-stop	Indicates the boiler temperature set on dip-switches 3 and 4 red
		Read only
tt	Tank temperature	Indicates the tank temperature set on dip-switches 5 and 6 red
		Read only
tSb	Tank thermo-stop	Indicates the boiler thermo-stop set on dip-switches 1 and 2 red
		Read only
fU	Firmware version	Indicates the firmware version installed on the power board
		Read only

PROGRAMMED MAINTENANCE

Once 80,000 wash cycles are completed, the LED on the display shown with the  symbol will light up to indicate that maintenance is required.

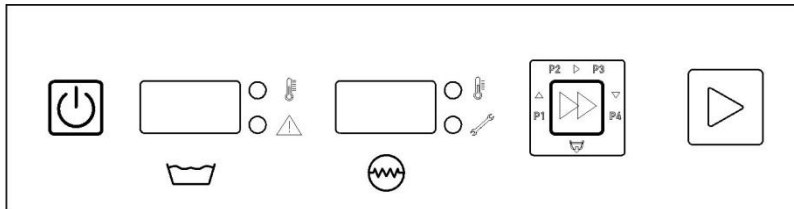

In addition to cleaning limescale and checking that all critical components function correctly, maintenance also includes **replacing detergent and rinse aid pipes inside the dispensers.**

NOTE

Performing programmed maintenance prevents sudden failures, thereby extending the dishwasher life span.

After having performed maintenance and replaced the detergent and rinse aid pipes, you can reset the alarm:

- Turn the dishwasher off (OFF)
- Hold down the PROGRAM SELECTION and CYCLE START buttons simultaneously
- The **Par** code will appear on the display followed by the indication of the executed wash cycles
- Reset the cycles and eliminate the message on the display by holding down the CYCLE START BUTTON
- While holding down the button, the display will show the flashing **rSt** (reset) message
- Continue to hold it down until the **rSt** message is replaced with 0 (reset cycles)
- If you do not touch any button for 20", you will exit the menu
- Exit the menu intentionally by holding down the ON/OFF button

Maintenance program

The following is a list of periodic technical maintenance operations to be performed by a specialised technician who must issue the report verifying the following:

MAINTENANCE	FREQUENCY	NOTES
General visual inspection by the technician who installed the dishwasher	Upon installation	The technician must issue a report confirming that the dishwasher functions properly. The report must include the date of the works, the signature of the technician and the signature of the customer/maintenance manager of the premises.
General visual inspection by the technician who installed the dishwasher. Check the general condition of the internal components, verify that the dispensers work and make sure that there are no liquid leaks from the dispensers or water leaks from the hydraulic circuit, including the pumps. Check the condition of the water loading and draining pipe connections	6 months after the first installation	
Check the functionality and wear of all components, and replace, if necessary Make sure the boiler is clean (empty it and check for limescale) Check the boiler resistance gasket Check for leaks from the wash pump Make sure the hydraulic circuit is intact Make sure the loading pipe is intact Make sure the drain pipe is intact Check the condition of the water loading and draining pipe connections Check the tightness of the clamps Make sure the electrical wiring is intact (replace any wires that are damaged due to external/environmental causes) Make sure the temperature probes are intact and the detected temperature is correct Check all electrical connections (faston, terminal block, electrical resistance terminals) Check that all the wires are tightened correctly in the contactor terminals, if present (three-phase models) Check the electric cable, plug and/or connections to the panel Make sure the air trap is intact and clean Check that the pressure switch functions properly Check that the solenoid valve functions properly Clean the filter of the solenoid valve Replace the detergent and rinse aid dispenser pipes even if the machine has been used partially for 12 months. Replace the carbographite bushings of the impellers to always guarantee correct rinsing	Every 12 months	If the technician should detect further anomalies during the verification and/or replacement of the components (which must take place with original spare parts), they will have to make the necessary repairs. If it is impossible to carry out the repair immediately, the dishwasher must not be used and an “out of order” sign must be affixed. Once the checks/repairs are completed, the technician will issue the report confirming that the dishwasher functions properly. The report must include the date of the works, the signature of the technician and the signature of the customer/maintenance manager of the premises.

Carry out all the intended checks for every 12 months and also: The following components must be replaced with original spare parts : Wash pump gaskets Water loading pipe Water drain pipe Seal of the boiler resistance Tank pressure switch (and boiler, if present) Solenoid valves	Every 24 months	Follow the instructions in the 12-month notes
---------------------------------------------------------------------------------------------------------------------------------------------------------------------------------------------------------------------------------------------------------------------------------------------------------------------	-----------------	-----------------------------------------------

Failure to comply with the above checks and the technician's failure to issue the brief reports will render the product warranty null and void. The Manufacturer is not liable for malfunctions and/or damage caused by negligence and failure to observe the periodic maintenance rules indicated in this use and maintenance manual.

Basic periodic/annual maintenance kit

The basic component kits for periodic maintenance are listed below, which must be replaced annually:

KIT1M - UNDERCOUNTER DISHWASHER AND GLASSWASHER ANNUAL MAINTENANCE KIT		
Component	Description	Q.ty
1216	Silicone pipe for rinse aid dispenser with fittings and check valve	1
1420	Light blue pipe 6x4 for the rinse aid dispenser	2.5
1217	Santoprene pipe for detergent dispenser, complete with fittings	1
1421	Yellow pipe 6x4 for detergent dispenser	2.5
503	Two-wire clamp Ø6-6.7	1
104465	Gasket for overflow NBR75 black	1
104100	Carbographite bush Ø14.1mm for wash/rinse impeller	4

KIT2M - WAREWASHER AND HOOD TYPE DISHWASHER ANNUAL MAINTENANCE KIT		
Component	Description	Q.ty
1216	Silicone pipe for rinse aid dispenser with fittings and check valve	1
1420	Light blue pipe 6x4 for the rinse aid dispenser	2.5
1217	Santoprene pipe for detergent dispenser, complete with fittings	1
1421	Yellow pipe 6x4 for detergent dispenser	2.5
503	Two-wire clamp Ø6-6.7	1
104465	Gasket for overflow NBR75 black	1
104100	Carbographite bush Ø14.1mm for rinse impeller	4
104110	Carbographite bush Ø26mm for wash impeller	4

DEFINED ALARMS

The following is a list of the defined alarms together with a short explanation. Not all alarms can be self-reset, i.e. they remain until the machine has been switched off and turned on again.

The alarm warning is displayed with:

- the ALARM LIGHT flashing
- the “AL” message on the LEFT DIGIT LEDs
- the alarm code on the RIGHT DIGIT LEDs

Alarm Code	Alarm Description	Checks performed by final user	Checks performed by repair technician
AL-01	Faulty boiler probe and tank probe: the temperature probes are both faulty. Heating is disabled	Request intervention of a technician	1- Remove and replace the probe connector on the power board 2- Replace the probes
AL-02	Faulty boiler probe: the boiler probe does not seem to be connected; it is interrupted or shorted Boiler heating is disabled	Request intervention of a technician	1- Check that the temperature probe is connected correctly on the power board 2- Check that the temperature probe terminal is connected correctly 3- Replace the probe
AL-03	Faulty tank probe: the tank probe does not seem to be connected; it is interrupted or shorted Boiler heating is disabled	Request intervention of a technician	1- Check that the temperature probe is connected correctly on the power board 2- Check that the temperature probe terminal is connected correctly 3- Replace the probe
AL-04	Tank loading timeout: the tank has not filled within the maximum time foreseen	1- Valve of water mains does not supply water 2- Overflow not inserted or inserted incorrectly 3- Rinse jets obstructed 4- Water loading pipe squashed 5- Upstream water softener not working	1- Solenoid valve filter obstructed 2- Solenoid valve not working 3- Pressure switch not working 4- Perforated air break 5- Circuit board RL2 relay damaged 6- Boiler clogged with limestone
AL-05	Drain timeout: the tank pressure switch did not open at the end of the total drain cycle	1- Overflow inserted 2- Drain pipe bent, choked or clogged	1- Filter clogged 2- Drain pipe clogged 3- Drain pump plugs damaged 4- Drain pump damaged 5- Circuit board RL1 relay damaged
AL-06	Heating timeout: the dishwasher did not heat the water within the intended maximum time. Heating is disabled	Request intervention of a technician	1- Three-phase electric plug connected incorrectly 2- Three-phase power fuses blown 3- Tank or boiler resistance power plugs disconnected or damaged 4- Tank resistance damaged 5- Boiler resistance damaged 6- Circuit board RL6 or RL7 relay damaged 7- Three-phase heating contactor damaged 8- Tank pressure switch damaged 9- Tripped Tank safety thermostat 10- Tripped boiler safety thermostat

