



DEFENDER™ 3300

Bench Scales



Bench Scales for Basic Industrial Applications

The Defender 3000 Series bench scales are ideal for general weighing, simple counting and checkweighing applications in production, packaging, warehouse, inventory, shipping and receiving areas. The Defender 3000 Series features a simple, yet rugged tubular-frame base design and indicators with tactile keys, multicolor backlit LCD display, AC or battery operation and flexible mounting capabilities.

Unique Features:

- Results are clearly shown using the large, bright backlit LCD display. In Checkweighing mode display changes color (yellow/green/red) to alert when within the target weight range.
- This tough industrial scale features a 304-stainless steel platform, powder-coated steel tubular frame, column and IP65 aluminum load cell. Indicator features a durable ABS housing and powder coated steel mounting bracket, IP54 protection rate with the optional dust cover.
- Features software for Parts Counting, Checkweighing and Totalization. Includes RS232 with optional USB Device or Ethernet for printing or data connectivity. Approved models are equipped with EasyConnect™ solution.

DEFENDER™ 3300 Bench Scales

Specifications

Column Mount Bench Scale

Model	i-D33P15B1R1	i-D33P30B1R1	i-D33P60B1R1	i-D33P60B1L2	i-D33P150B1L2
Capacity x Default Readability	15 kg x 2 g	30 kg x 5 g	60 kg x 10 g	60 kg x 10 g	150 kg x 20 g
Maximum Displayed Resolution	1:7,500	1:6,000			1:7,500
Linearity/Repeatability	±1d				
Certified Model	i-D33P15B1R1-M	i-D33P30B1R1-M	i-D33P60B1R1-M	i-D33P60B1L2-M	i-D33P150B1L2-M
Capacity x Certified/Approved Readability	15 kg x 5 g	30 kg x 10 g	60 kg x 20 g		150 kg x 50 g
Maximum Certified Resolution	1:3,000				
Indicator	ABS indicator				
Column	330 mm powder-coated steel			680 mm powder-coated steel	
Base Construction	Stainless steel removable weighing platform, powder-coated steel base construction, silicon sealed IP65 aluminum loadcell against moisture				
Safe Overload Capacity	150% of maximum capacity				
Stabilization Time	Within 1 second				
Operating Temperature Range	-10°C to 40°C				
Scale Dimensions (A x B x C x D x E x F)	355 x 305 x 121.8 x 75 x 541.6 x 489.1 mm			550 x 420 x 134 x 80 x 896.1 x 685.6 mm	
Shipping Dimensions (L x W x H)	642 x 497 x 212 mm M models: 495 x 455 x 373 mm			857 x 564 x 225 mm M models: 1022 x 687 x 247 mm	
Approx. Net Weight	10.4 kg			16.9 kg	
Approx. Shipping Weight	13.4 kg			21 kg	

Model	i-D33P150B1X2	i-D33P300B1X2	i-D33P300B1V3	i-D33P600B1V3
Capacity x Default Readability	150 kg x 20 g	300 kg x 50 g	300 kg x 50 g	600 kg x 100 g
Maximum Displayed Resolution	1:7,500	1:6,000		
Linearity/Repeatability	±1d			
Certified Model	i-D33P150B1X2-M	i-D33P300B1X2-M	i-D33P300B1V3-M	i-D33P600B1V3-M
Capacity x Certified/Approved Readability	150 kg x 50 g	300 kg x 100 g		600 kg x 200 g
Maximum Certified Resolution	1:3,000			
Indicator	ABS indicator			
Column	680 mm powder-coated steel		980 mm powder-coated steel	
Base Construction	Stainless steel removable weighing platform, powder-coated steel base construction, silicon sealed IP65 aluminum loadcell against moisture			
Safe Overload Capacity	150% of maximum capacity			
Stabilization Time	Within 1 second			
Operating Temperature Range	-10°C to 40°C			
Scale Dimensions (A x B x C x D x E x F)	650 x 500 x 150 x 90 x 894.6 x 784.6 mm		800 x 600 x 154.1 x 90 x 1194.6 x 933.1 mm	
Shipping Dimensions (L x W x H)	1022 x 687 x 247 mm M models: 1022 x 687 x 247 mm		1165 x 780 x 235 mm M models: 1175 x 790 x 245 mm	
Approx. Net Weight	27 kg		45.5 kg	
Approx. Shipping Weight	30.5 kg		49.5 kg	

DEFENDER™ 3300 Bench Scales

Specifications

Front Mount Bench Scale

Model	i-D33P15B1R5	i-D33P30B1R5	i-D33P60B1R5	i-D33P60B1L5	i-D33P150B1L5	i-D33P150B1X5	i-D33P300B1X5
Capacity x Default Readability	15 kg x 2 g	30 kg x 5 g	60 kg x 10 g	60 kg x 10 g	150 kg x 20 g	150 kg x 20 g	300 kg x 50 g
Maximum Displayed Resolution	1:7,500	1:6,000		1:7,500		1:6,000	
Linearity/ Repeatability	±1d						
Certified Model	i-D33P15B1R5-M	i-D33P30B1R5-M	i-D33P60B1R5-M	i-D33P60B1L5-M	i-D33P150B1L5-M	i-D33P150B1X5-M	i-D33P300B1X5-M
Capacity x Certified/ Approved Readability	15 kg x 5 g	30 kg x 10 g	60 kg x 20 g		150 kg x 50 g		300 kg x 100 g
Maximum Certified Resolution	1:3,000						
Indicator	ABS indicator						
Column	304 stainless steel front-mount bracket with handle						
Base Construction	Stainless steel removable weighing platform, powder-coated steel base construction, silicon sealed IP65 aluminum loadcell against moisture						
Safe Overload Capacity	150% of maximum capacity						
Stabilization Time	Within 1 second						
Operating Temperature Range	-10°C to 40°C						
Scale Dimensions (A x B x C x D x E x F)	355 x 305 x 121.8 x 75 x 130 x 645.5 mm			550 x 420 x 134 x 80 x 132.9 x 842 mm		650 x 500 x 150 x 90 x 133 x 941 mm	
Shipping Dimensions (L x W x H)	857 x 564 x 225 mm M models: 495 x 455 x 373 mm			1022 x 687 x 247 mm M models: 1022 x 687 x 247 mm			
Approx. Net Weight	9.6 kg			15.5 kg		25.7 kg	
Approx. Shipping Weight	12 kg			19.6 kg		29.2 kg	

Indicators

Model	i-DT33P
Construction	ABS housing, painted steel mounting bracket
Protection	IP54 (with optional dust cover)
Weighing Units	Kilogram, Gram, Pound, Ounce, Pound: Ounce (Kilogram, Gram only for M models)
Application Modes	Weighing, Parts Counting, Checkweighing and Totalization
Display	6-digit, 7-segment LCD display with multi-color backlight, 45 mm high digits
Check Indicator	3 Color (red, green, yellow) backlight
Keyboard	4 function keys
Auto-zero Tracking	Off, 0.5 d, 1 d or 3 d
Zeroing Range	2% or 100% of capacity
Interface	RS232 included
	Optional USB, Ethernet
Power	100-240 VAC / 50/60 Hz Universal Power Supply or C cell battery (Not included)
	Optional Rechargeable battery
Battery Life	Up to 360 hours (C cell battery) or 100 hours continuous use with optional rechargeable battery with backlight off
Calibration	Zero, Span or 3 point-Linear

DEFENDER™3300 Bench Scales

Outline Dimensions

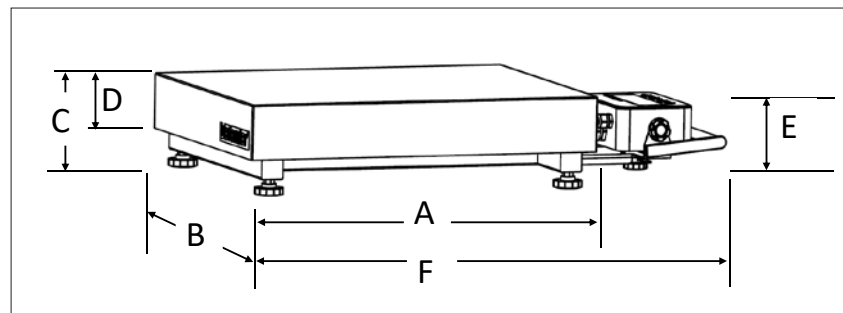
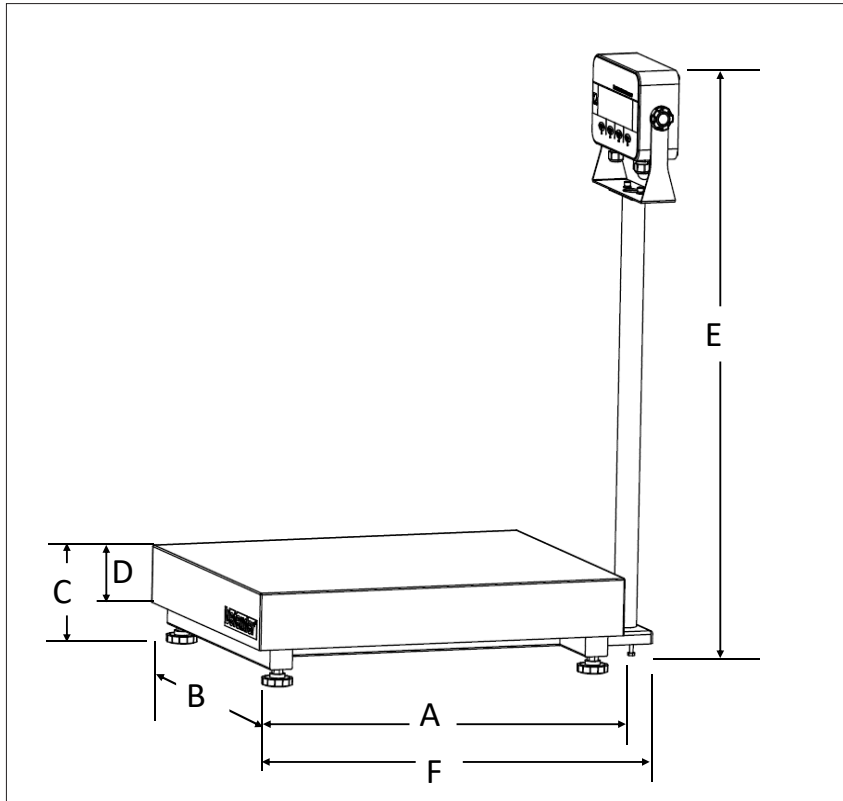

Accessories

Ethernet Kit.....	30429666
USB Device Kit i-DT33.....	30699120
Dust Cover (5) i-DT33.....	30699121
Rechargeable Battery Kit i-DT33P.....	30699122
Wheel Kit, Defender Series.....	30372146
Wheel Kit SST Defender Series.....	30616409
Carrying Handle Kit i-DT33.....	30696600
SF40A Printer.....	30064202
Cable RS232 i-DT33P.....	80500525

Column Kit for i-DT33 indicator:

Column Kit, 330 mm, SST.....	30696595
Column Kit, 680 mm, SST.....	30696596
Column Kit, 330 mm, CS.....	30696597
Column Kit, 680 mm, CS.....	30696598
Column Kit, 980 mm, CS.....	30696599

Compliance

- **Metrology:** EN45501 (Scale: T12209; Indicator: TC12208; Load Cell: OIML R60/2017-A-NL1-21.19 / TC12115; R60/2017-A-NL1-21.20 / TC12116; R60/2017-A-NL1-21.21 / TC12117; R60/2017-A-NL1-21.22 / TC12114).
- **Product Safety:** IEC/EN 61010-1; CAN/CSA C22.2 61010-1; UL61010-1
- **Electromagnetic Compatibility:** IEC/EN 61326-1 Class B, basic environments; FCC Part 15 Class A; Canada ICES-003 Class A
- **Ingress Protection:** IEC 60529 – IP54 (for indicator), IEC 60529 – IP65 (for load cell)
- **Compliance Marks:** CE, UKCA
- **Other:** WEEE, RoHS

OHAUS Europe GmbH

Heuwinkelstrasse 3,
8606 Nänikon,
Switzerland

e-mail: ssc@ohaus.com
Tel: 0041 22 567 53 19
e-mail: tsc@ohaus.com
Tel: 0041 22 567 53 20

www.ohaus.com

The management system governing the manufacture of this product is ISO 9001:2015 certified.

