

# Swift

- ✔ Intelligent Slicing Concept for automatic slicing management
- ✔ Mass production multiformat slicer
- ✔ Ergonomics and productivity
- ✔ Fast cutting cycle
- ✔ Economical
- ✔ Versatility

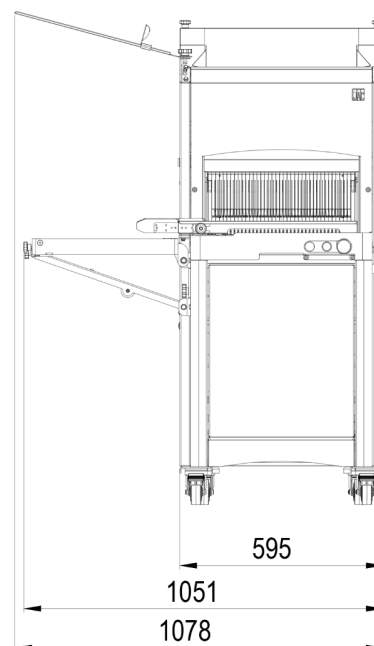
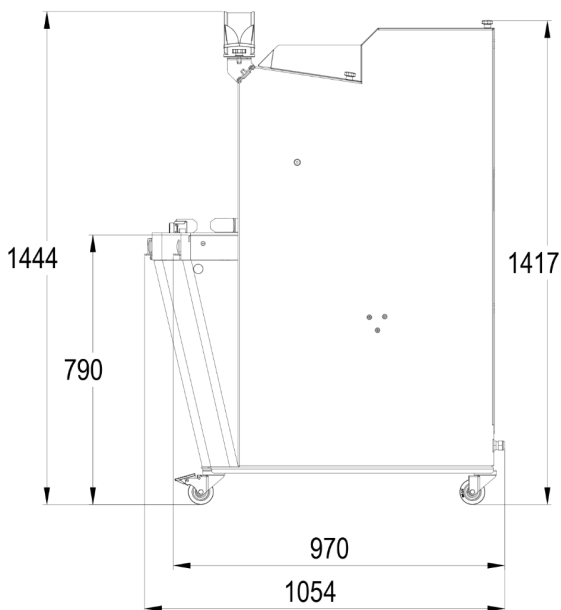

## SPECIFICATIONS

|                                        |                |
|----------------------------------------|----------------|
| Max. loaf dimensions in cm (L x W x H) | 44 x 31 x 16   |
| Motor power in kW                      | 0.49           |
| Net weight (in kg)                     | 165            |
| Blade type and dimensions in mm        | 13 x 0.5 steel |
| ISC extended mode selector             | •              |

## TECHNICAL SPECIFICATIONS

|                           |                                                                                                              |
|---------------------------|--------------------------------------------------------------------------------------------------------------|
| Slice thickness in mm     | 9,10,11,12,13,14,15,16,17,18                                                                                 |
| Loaf pusher height        | Extra low (50mm),Low (80mm),High (100mm)                                                                     |
| Power supply              | 230V single phase ,230V three-phase ,400V three-phase                                                        |
| Options (Additional cost) | Heavy duty motor, 4 cm height adjustment, Daily adding counter, Special blades, Bag closing device with tape |

## MAIN STRENGTHS



### ISC® extended mode selector

Intelligent Slicing Control (JAC patent) is an automatic pressure and slicing speed control system. It adapts the cutting action according to the consistency of the bread. No manual setting needed. The ISC® with extended mode selector provides two extra automatic modes, to adapt to extreme cutting condition of very fresh breads or the need for particularly fast cutting rate.

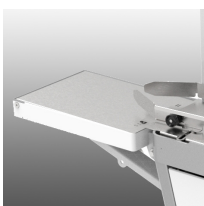

### Foldable bag blower (option)

Saves packaging time.

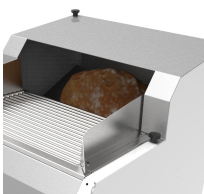

### Secure roll tipping area

The tilting zone makes the transition between the loading table and the cutting table. With each passage of a loaf, the tilting zone rotates to deposit the loaf on the cutting area. This area is secured by cells that prevent it from functioning if the operator puts his hand or anything else in it. A mechanical barrier blocks the passage of other loaves during tilting.



### Removable crumb collector

Accessible by tilting the front, cylinder-assisted door. 18 litre capacity.



### Front loading area.

The loading area consists of rollers on ball bearings to automatically direct loaves to the loaf changeover area. Given that it is located facing the operator, this simplifies the handling of loaves considerably. It is not necessary to make adjustments for different loaf formats, as the slicer adapts, saving you time and improving ergonomics.



### Sliced loaf delivery area.

The delivery area is located at the correct height to facilitate the handling of loaves sliced. As it is provided with holes, any crumbs fall into the recovery tray.